

## Fixed Frequency, 99% Duty Cycle Peak Current Mode Notebook System Power Controller

### FEATURES

- Input Voltage Range: 4.5 V to 28 V
- Output Voltage Range: 1 V to 12 V
- Selectable Light Load Operation (Continuous / Auto Skip / Out-Of-Audio™ Skip)
- Programmable Droop Compensation
- Voltage Servo Adjustable Soft Start
- 200 kHz to 1 MHz Fixed Frequency PWM
- Current Mode Architecture
- 180° Phase Shift Between Channels
- Resistor or Inductor DCR Current Sensing
- Powergood Output for each channel
- OCL/OVP/UVP/UVLO protections
- Current Monitor Output for CH1
- Thermal Shutdown (Non-latch)
- Output Discharge Function (Disable option)
- Integrated Boot Strap MOSFET Switch
- QFN32 (RTV)

### APPLICATIONS

- Notebook Computer System and I/O Bus
- Point of load in LCD TV, MFP

### DESCRIPTION

The TPS51221 is a dual synchronous buck regulator controller with 2 LDOs. It is optimized for 5V/3.3V system controller, enabling designers to cost effectively complete 2-cells to 4-cells notebook system power supply. The TPS51221 supports high efficiency, fast transient response and 99% duty cycle operation. It supports supply input voltages ranging from 4.5V to 28V, and output voltages from 1V to 12V. Peak current mode supports stability operation with lower ESR capacitor and output accuracy. The high duty (99%) operation and wide input/ output voltage range supports flexible design for small mobile PCs and a wide variety of other applications. The fixed frequency can be adjusted from 200 kHz to 1MHz by a resistor, and each channel runs 180° out of phase. The TPS51221 can also synchronize to the external clock, and the interleaving ratio can be adjusted by its duty. The TPS51221 is available in the 32 pin 5x5 QFN package and is specified from -40°C to 85°C.

### TYPICAL APPLICATION CIRCUIT

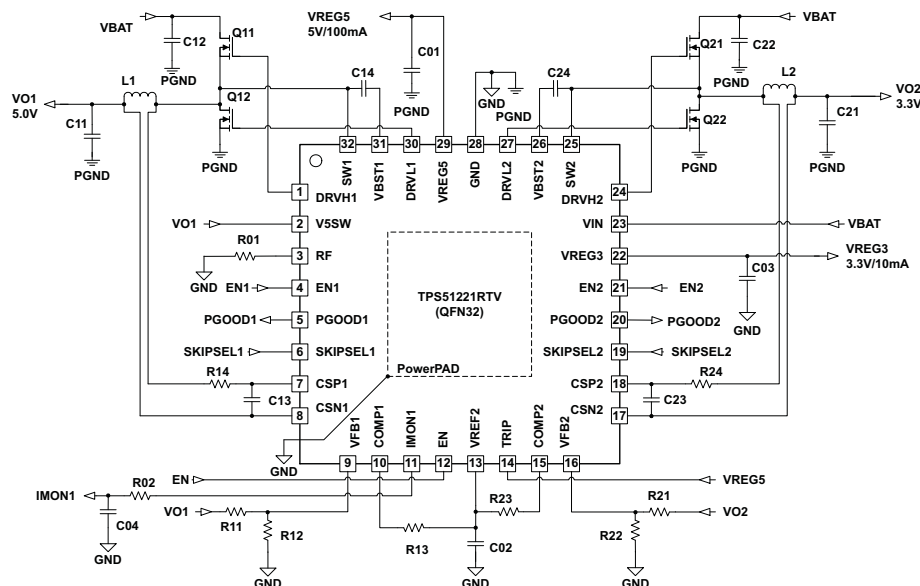

Please be aware that an important notice concerning availability, standard warranty, and use in critical applications of Texas Instruments semiconductor products and disclaimers thereto appears at the end of this data sheet.

Out-Of-Audio, D-CAP, PowerPAD are trademarks of Texas Instruments.

FUNCTIONAL BLOCK DIAGRAM

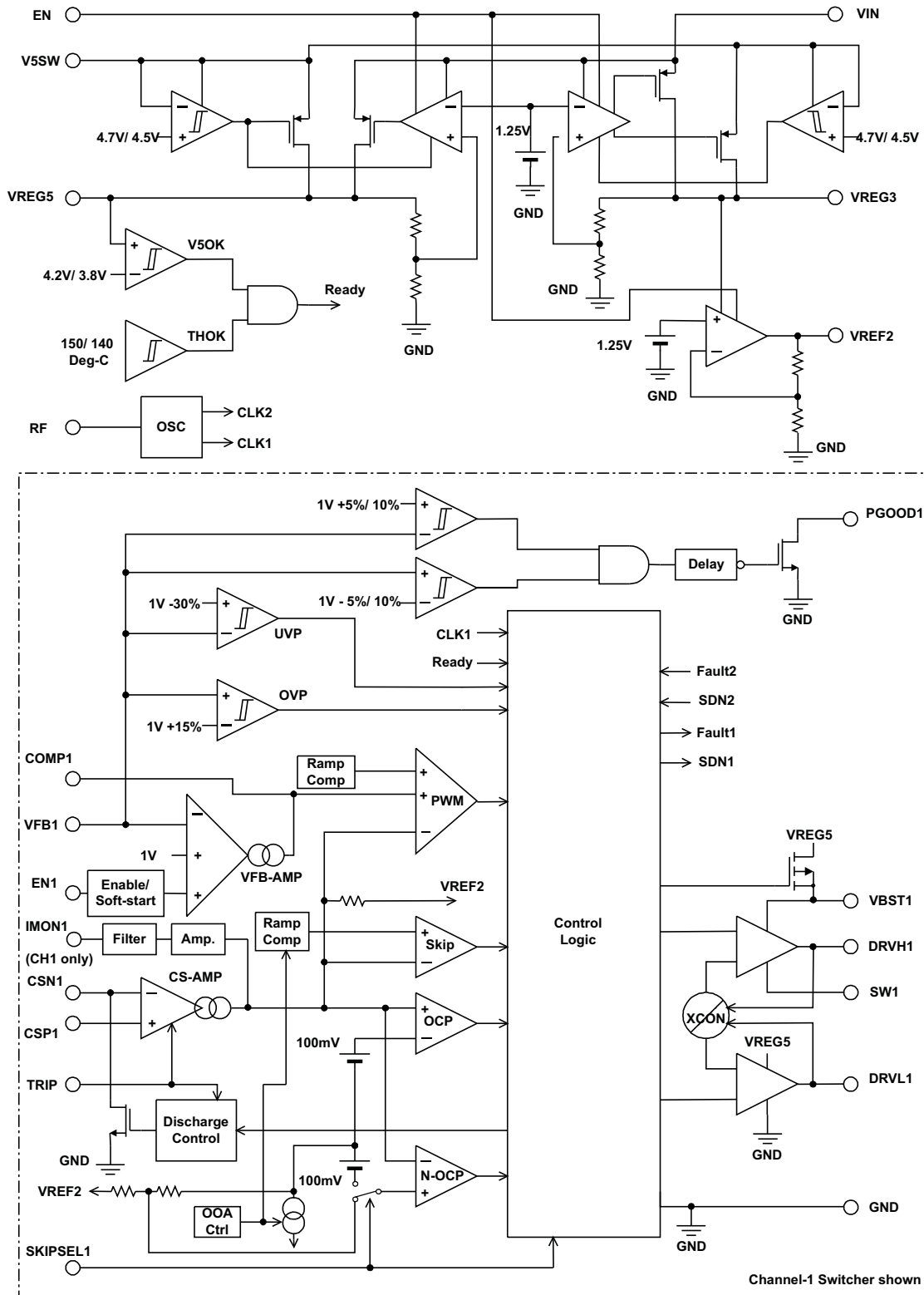

**ORDERING INFORMATION<sup>(1)</sup>**

T <sub>A</sub>	PACKAGE	ORDERABLE PART NUMBER	PINS	OUTPUT SUPPLY	MINIMUM ORDER QUANTITY	ECO PLAN
-40°C to 85°C	PLASTIC QUAD FLAT PACK (QFN)	TPS51221RTVT	32	Tape and reel	250	Green (RoHS and no Sb/Br)
		TPS51221RTVR		Tape and reel	3000	

(1) For the most current package and ordering information, see the Package Option Addendum at the end of this document, or see the TI website at [www.ti.com](http://www.ti.com).

**ABSOLUTE MAXIMUM RATINGS<sup>(1)</sup>**

over operating free-air temperature range (unless otherwise noted)

		VALUE	UNIT
Input voltage range <sup>(2)</sup>	VIN	-0.3 to 30	V
	VBST1, VBST2	-0.3 to 35	V
	VBST1, VBST2 <sup>(3)</sup>	-0.3 to 7	V
	SW1, SW2	-2 to 30	V
	CSP1, CSP2, CSN1, CSN2	-1 to 13.5	V
	EN, EN1, EN2, VFB1, VFB2, TRIP, SKIPSEL1, SKIPSEL2	-0.3 to 7	V
	V5SW	-0.3 to 7	V
	V5SW (to VREG5) <sup>(4)</sup>	-7 to 7	V
Output voltage range <sup>(2)</sup>	DRVH1, DRVH2	-2 to 35	V
	DRVH1, DRVH2 <sup>(3)</sup>	-0.3 to 7	V
	DRVL1, DRVL2, COMP1, COMP2, VREG5, RF, VREF2, IMON1 PGOOD1, PGOOD2	-0.3 to 7	V
	VREG3	-0.3 to 3.6	V
Operating junction temperature range, T <sub>J</sub>		-40 to 125	°C
Storage temperature, T <sub>st</sub>		-55 to 150	°C

(1) Stresses beyond those listed under *absolute maximum ratings* may cause permanent damage to the device. These are stress ratings only and functional operation of the device at these or any other conditions beyond those indicated under *recommended operating conditions* is not implied. Exposure to absolute-maximum-rated conditions for extended periods may affect device reliability.

(2) All voltage values are with respect to the network ground terminal unless otherwise noted.

(3) Voltage values are with respect to the corresponding SW terminal.

(4) When EN is high and V5SW is grounded, or voltage is applied to V5SW when EN is low.

**DISSIPATION RATINGS (2 oz Trace and Copper Pad with Solder)**

PACKAGE	T <sub>A</sub> < 25°C POWER RATING	DERATING FACTOR ABOVE T <sub>A</sub> = 25°C	T <sub>A</sub> = 85°C POWER RATING
32 pin RTV	1.7 W	17 mW/°C	0.7 W

**RECOMMENDED OPERATING CONDITIONS**

		MIN	TYP	MAX	UNIT
Supply voltage	VIN	4.5		28	V
	V5SW	-0.8		6	
I/O voltage	VBST1, VBST2, DRVH1, DRVH2	-0.1		33	V
	DRVH1, DRVH2 (wrt SW1, 2)	-0.1		6	
	SW1, SW2	-1.6		28	
	CSP1, CSP2, CSN1, CSN2	-0.8		13	
	EN, EN1, EN2, VFB1, VFB2, TRIP, DRVL1, DRVL2, COMP1, COMP2, VREG5, RF, VREF2, PGOOD1, PGOOD2, SKIPSEL1, SKIPSEL2, IMON1	-0.1		6	
	VREG3	-0.1		3.5	
Operating free-air temperature, T <sub>A</sub>		-40		85	°C

**ELECTRICAL CHARACTERISTICS**

over operating free-air temperature range, EN=3.3V, VIN=12V, V5SW=5V (unless otherwise noted)

PARAMETER		TEST CONDITIONS	MIN	TYP	MAX	UNIT
<b>SUPPLY CURRENT</b>						
$I_{V\text{INSDN}}$	VIN shutdown current	VIN shutdown current, $T_A = 25^\circ\text{C}$ , No Load, EN = 0V, V5SW = 0 V		7	15	$\mu\text{A}$
$I_{V\text{INSTBY1}}$	VIN Standby Current 1	VIN shutdown current, $T_A = 25^\circ\text{C}$ , No Load, EN1=EN2=V5SW = 0 V		80	120	$\mu\text{A}$
$I_{V\text{BATSTBY}}$	Vbat Standby Current	Vbat standby current, $T_A = 25^\circ\text{C}$ , No Load SKIPSEL2=2V, EN2=open, EN1=V5SW=0V <sup>(1)</sup>		500		$\mu\text{A}$
$I_{V5\text{SW}}$	V5SW Supply Current	V5SW current, $T_A = 25^\circ\text{C}$ , No Load, ENx=5V, VFBx=1.05 V		1.2		mA
				1.4		mA
<b>VREF2 OUTPUT</b>						
$V_{V\text{REF2}}$	VREF2 Output Voltage	$I_{V\text{REF2}} < \pm 10 \mu\text{A}$ , $T_A = 25^\circ\text{C}$	1.98	2.00	2.02	V
		$I_{V\text{REF2}} < \pm 100 \mu\text{A}$ , $4.5\text{V} < \text{VIN} < 25\text{V}$	1.97	2.00	2.03	
<b>VREG3 OUTPUT</b>						
$V_{V\text{REG3}}$	VREG3 Output Voltage	V5SW = 0 V, $I_{V\text{REG3}} = 0\text{ mA}$ , $T_A = 25^\circ\text{C}$	3.279	3.313	3.347	V
		V5SW = 0 V, $0\text{ mA} < I_{V\text{REG3}} < 10\text{ mA}$ , $5.5\text{ V} < \text{VIN} < 25\text{ V}$	3.135	3.300	3.400	
$I_{V\text{REG3}}$	VREG3 Output Current	VREG3 = 3 V	10	15	20	mA
<b>VREG5 OUTPUT</b>						
$V_{V\text{REG5}}$	VREG5 Output Voltage	V5SW = 0 V, $I_{V\text{REG5}} = 0\text{ mA}$ , $T_A = 25^\circ\text{C}$	4.99	5.04	5.09	V
		V5SW = 0 V, $0\text{ mA} < I_{V\text{REG5}} < 100\text{ mA}$ , $6\text{ V} < \text{VIN} < 25\text{ V}$	4.90	5.03	5.15	
		V5SW = 0 V, $0\text{ mA} < I_{V\text{REG5}} < 100\text{ mA}$ , $5.5\text{ V} < \text{VIN} < 25\text{ V}$	4.50	5.03	5.15	
$I_{V\text{REG5}}$	VREG5 Output Current	V5SW = 0 V, VREG5 = 4.5 V	100	150	200	mA
		V5SW = 5 V, VREG5 = 4.5 V	200	300	400	
$V_{\text{THV5SW}}$	Switchover Threshold	Turning on	4.55	4.7	4.8	V
		Hysteresis	0.15	0.20	0.25	
$t_{dV5\text{SW}}$	Switchover Delay	Turning on		7.7		ms
$R_{V5\text{SW}}$	5V SW Ron	$I_{V\text{REG5}} = 100\text{ mA}$		0.5		$\Omega$
<b>OUTPUT</b>						
$V_{V\text{FB}}$	VFB Regulation Voltage Tolerance	$T_A = 25^\circ\text{C}$ , No Load	0.9925	1.000	1.0075	V
		$T_A = -40^\circ\text{C}$ to $85^\circ\text{C}$ , No Load	0.990	1.000	1.010	
$I_{V\text{FB}}$	VFB Input Current	$I_{V\text{FB}} \text{ VFBx} = 1.05\text{ V}$ , $\text{COMPx} = 1.8\text{ V}$ , $T_A = 25^\circ\text{C}$		-50	50	nA
$R_{\text{Dischg}}$	CSNx Discharge Resistance	ENx = 0 V, CSNx = 0.5 V, $T_A = 25^\circ\text{C}$		20	40	$\Omega$
<b>VOLTAGE TRANSCONDUCTANCE AMPLIFIER</b>						
$G_{mV}$	Gain	$T_A = 25^\circ\text{C}$		500		$\mu\text{S}$
$V_{\text{ind}}$	Differential Input Voltage Range		-30		30	mV
$I_{\text{COMPSNK}}$	COMP Maximum Sink Current	COMPx = 1.8 V		33		$\mu\text{A}$
$I_{\text{COMPSRC}}$	COMP Maximum Source Current	COMPx = 1.8 V		-33		$\mu\text{A}$

(1) Specified by design. Detailed external condition follows the application circuit of [Figure 53](#)

**ELECTRICAL CHARACTERISTICS (continued)**

over operating free-air temperature range, EN=3.3V, VIN=12V, V5SW=5V (unless otherwise noted)

PARAMETER		TEST CONDITIONS	MIN	TYP	MAX	UNIT	
<b>CURRENT AMPLIFIER</b>							
G <sub>C</sub>	Gain	TRIP = 0V/2V, CSN = 5V, T <sub>A</sub> = 25°C <sup>(2)</sup>	3.333				
		TRIP=3.3V/5V, CSN=5V, T <sub>A</sub> = 25°C <sup>(2)</sup>	1.667				
V <sub>IC</sub>	Common mode input voltage range		0		13	V	
V <sub>ID</sub>	Differential input voltage range	T <sub>A</sub> = 25°C	-75		75	mV	
<b>POWERGOOD</b>							
V <sub>THPG</sub>	PG threshold	PG in from lower	92.5%	95%	97.5%		
		PG in from higher	102.5%	105%	107.5%		
		PG hysteresis	5%				
I <sub>PG</sub>	PG sink current	PGOOD = 0.5 V	5			mA	
t <sub>PGDLY</sub>	PGOOD Delay	Delay for PG in	0.8	1	1.2	ms	
<b>SOFTSTART</b>							
t <sub>SSDYL</sub>	Soft start delay	Delay for Soft Start, ENx=Hi to SS-ramp starts	200			μs	
t <sub>SS</sub>	Soft start time	Internal soft start	960			μs	
<b>FREQUENCY AND DUTY CONTROL</b>							
f <sub>SW</sub>	Switching frequency	R <sub>f</sub> = 330 kΩ	273	303	333	kHz	
V <sub>THRF</sub>	RF Threshold	Lo to Hi	0.7	1.3	2.0	V	
		Hysteresis	0.2			V	
f <sub>SYNC</sub>	Sync Input Frequency Range	Specified by design	200		1000	kHz	
t <sub>ONMIN</sub>	Minimum On Time	V <sub>DRVH</sub> = 90% to 10%, No Load	120			150	ns
t <sub>OFFMIN</sub>	Minimum Off Time	V <sub>DRVH</sub> = 10% to 90%, No Load	290			440	ns
t <sub>D</sub>	Dead time	DRVH-off to DRVL-on	10	30	50	ns	
		DRVL-off to DRVH-on	30	40	70	ns	
V <sub>DTH</sub>	DRVH-off threshold	DRVH to GND <sup>(2)</sup>	1.0			V	
V <sub>DTL</sub>	DRVL-off threshold	DRVL to GND <sup>(2)</sup>	1.0			V	
<b>OUTPUT DRIVERS</b>							
R <sub>DRVH</sub>	DRVH resistance	Source, V <sub>VBST-DRVH</sub> = 0.1 V	1.7			5.0	Ω
		Sink, V <sub>DRVH-SW</sub> = 0.1 V	1.0			3.0	
R <sub>DRVL</sub>	DRVL resistance	Source, V <sub>V5IN-DRVL</sub> = 0.1 V	1.3			4.0	Ω
		Sink, V <sub>DRVL-PGND</sub> = 0.1 V	0.7			2.0	
<b>CURRENT SENSE</b>							
V <sub>OCL-ULV</sub>	Current limit threshold (Ultra Low Voltage)	TRIP = 0V/2V, T <sub>A</sub> = 25°C	27	31	35	mV	
		TRIP = 0V/2V	25	31	37		
V <sub>OCL-LV</sub>	Current limit threshold (Low Voltage)	TRIP = 3.3V/5V, T <sub>A</sub> = 25°C	56	60	64	mV	
		TRIP = 3.3V/5V	54	60	66		
V <sub>ZC</sub>	Zero cross detection comparator Offset	0.95V < CSNx < 12.6V	-4	0	4	mV	
V <sub>OCLN-ULV</sub>	Negative Current limit threshold (ULV)	TRIP = 0V/2V, T <sub>A</sub> = 25°C	-24	-31	-38	mV	
		TRIP = 0V/2V	-22	-31	-40		
V <sub>OCLN-LV</sub>	Negative Current limit threshold (LV)	TRIP = 3.3V/5V, T <sub>A</sub> = 25°C	-51	-60	-69	mV	
		TRIP = 3.3V/5V	-49	-60	-71		

(2) Specified by design.

**ELECTRICAL CHARACTERISTICS (continued)**

over operating free-air temperature range, EN=3.3V, VIN=12V, V5SW=5V (unless otherwise noted)

PARAMETER		TEST CONDITIONS	MIN	TYP	MAX	UNIT
<b>UVP, OVP AND UVLO</b>						
V <sub>OVP</sub>	OVP Trip Threshold	OVP detect	110%	115%	120%	
t <sub>OVPDLY</sub>	OVP Prop Delay			1.5		μs
V <sub>UVP</sub>	UVP Trip Threshold	UVP detect	65%	70%	73%	
t <sub>UVPDLY</sub>	UVP Delay		0.8	1	1.2	ms
V <sub>UVREF2</sub>	VREF2 UVLO Threshold	Wake up	1.7	1.8	1.9	V
		Hysteresis	75	100	125	mV
V <sub>UVREG3</sub>	VREG3 UVLO Threshold	Wake up	3.0	3.1	3.2	V
		Hysteresis	0.10	0.15	0.20	
V <sub>UVREG5</sub>	VREG5 UVLO Threshold	Wake up	4.1	4.2	4.3	V
		Hysteresis	0.35	0.40	0.44	V
<b>INTERFACE AND LOGIC THRESHOLD</b>						
V <sub>EN</sub>	EN Threshold	Wake up	0.8	1.0	1.2	V
		Hysteresis	0.1	0.2	0.3	
V <sub>EN12</sub>	EN1/EN2 Threshold	Wake up	0.45	0.50	0.55	V
		Hysteresis	0.1	0.2	0.3	
V <sub>EN12SS</sub>	EN1/EN2 SS Start threshold	SS-ramp start threshold at external soft start		1.0		V
V <sub>EN12SSEND</sub>	EN1/EN2 SS End threshold	SS-End threshold at external soft start		2.0		V
I <sub>EN12</sub>	EN1/EN2 Source Current	V <sub>EN1/EN2</sub> = 0V	1.5	2.0	2.6	μA
V <sub>SKIPSEL</sub>	SKIPSEL1/SKIPSEL2 Logic Setting Voltage	Continuous			1.5	V
		Auto Skip			2.1	
		OOA Skip (min 1/8 Fsw)			3.4	
		OOA Skip (min 1/16 Fsw)			3.8	
V <sub>TRIP</sub>	TRIP Logic Setting Voltage	V <sub>OCL-ULV</sub> , Discharge ON			1.5	V
		V <sub>OCL-ULV</sub> , Discharge OFF			2.1	
		V <sub>OCL-LV</sub> , Discharge OFF			3.4	
		V <sub>OCL-LV</sub> , Discharge ON			3.8	
I <sub>TRIP</sub>	TRIP Input Current	TRIP = 0V	-1		1	μA
		TRIP =5V	-1		1	
I <sub>SKIPSEL</sub>	SKIPSEL Input Current	SKIPSELx = 0 V	-1		1	μA
		SKIPSELx = 5 V	-1		1	
<b>BOOT STRAP SW</b>						
V <sub>FBST</sub>	Forward Voltage	V <sub>VREG5-VBST</sub> , I <sub>F</sub> = 10 mA, T <sub>A</sub> = 25°C		0.10	0.20	V
I <sub>BSTLK</sub>	VBST Leakage Current	VBST = 30 V, SW = 25 V		0.01	1.5	μA
<b>THERMAL SHUTDOWN</b>						
T <sub>SDN</sub>	Thermal SDN Threshold	Shutdown temperature <sup>(3)</sup>		150		°C
		Hysteresis <sup>(3)</sup>		10		

(3) Specified by design.

## ELECTRICAL CHARACTERISTICS (continued)

over operating free-air temperature range, EN=3.3V, VIN=12V, V5SW=5V (unless otherwise noted)

PARAMETER		TEST CONDITIONS	MIN	TYP	MAX	UNIT
<b>CURRENT MONITOR</b>						
G <sub>IMON</sub>	Current Monitor Gain	TRIP = 0V/2V		100		
		TRIP = 3.3V/5V		50		
V <sub>IMON</sub>	Current Monitor Output	TRIP = 0V/2V, V <sub>CSPx-CSNx</sub> = 30 mV, 0.95V < CNS <sub>x</sub> < 12.6V, T <sub>A</sub> = 25°C	2.65	2.95	3.25	V
		TRIP = 3.3V/5V, V <sub>CSPx-CSNx</sub> = 60 mV, 0.95V < CNS <sub>x</sub> < 12.6V, T <sub>A</sub> = 25°C	2.75	3.0	3.25	
V <sub>IMON-OFF</sub>	Current Monitor Output Offset	TRIP = 0V/2V, V <sub>CSPx-CSNx</sub> = 0 V, 0.95V < CNS <sub>x</sub> < 12.6V, T <sub>A</sub> = 25°C	-300		300	mV
		TRIP = 3.3V/5V, V <sub>CSPx-CSNx</sub> = 0 V, 0.95V < CNS <sub>x</sub> < 12.6V, T <sub>A</sub> = 25°C	-200		200	

## DEVICE INFORMATION

### PINOUT

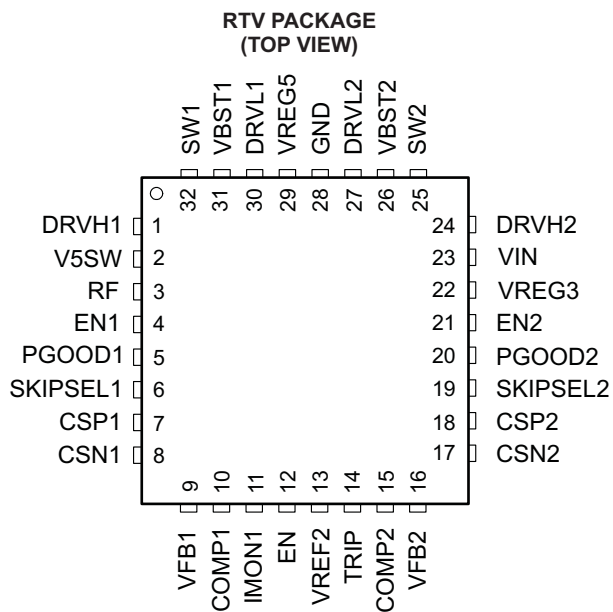

### TERMINAL FUNCTIONS

TERMINAL		I/O	DESCRIPTION
NAME	NO.		
DRVH1	1	O	High-side MOSFET gate driver outputs. Source 1.7Ω, sink 1.0Ω, SW-node referenced floating driver. Drive voltage corresponds to VBST to SW voltage.
DRVH2	24		
SW2	25	I/O	High-side MOSFET gate driver returns.
SW1	32		
VREG3	22	O	Always alive 3.3V, 10mA Low Dropout Linear Regulator Output. Bypass to (signal) GND by more than 1μF ceramic capacitor. Runs from VIN supply or from VREG5 when it is switched over to V5SW input.
EN1	4	I	Channel 1 and Channel 2 SMPS Enable Pins. . When turning on, apply greater than 0.55V and less than 6V. Connect to GND to disable. Adjustable soft-start capacitance to be attached here.
EN2	21		
PGOOD1	5	O	Power Good window comparator outputs for channel 1 and 2. The applied voltage should be less than 6V and recommended pull-up resistance value is from 100kΩ to 1MΩ.
PGOOD2	20		
SKIPSEL1	6	I	Skip Mode Selection pin. GND: Continuous Conduction Mode VREF2: Auto Skip VREG3: OOA Auto Skip, max 7 skips (use with <400 kHz) VREG5: OOA Auto Skip, max 15 skips (use with more than 400 kHz)
SKIPSEL2	19		
CSP1	7	I/O	Current sense comparator inputs (+). An RC network with high quality X5R or X7R ceramic capacitor should be used to extract voltage drop across DCR. 0.1μF is a good value to start design. Refer to current sensing scheme section for more details.
CSP2	18		
CSN1	8	I	Current sense comparator inputs (-). (See the current sensing scheme section.) Used as power supply for the current sense circuit for 5V or higher output voltage setting. Also, used for output discharge.
CSN2	17		
VFB1	9	I	SMPS Feedback Inputs. Connect the feedback resistor divider and should refer to (signal) GND.
VFB2	16		
COMP1	10	I	Loop Compensation Pin (Error Amplifier Output). Connect R (and C if required) from this pin to VREF2 for proper loop compensation with current mode operation. Ramp compensation adjustable pin for D-CAP™ mode, connect R from this pin to VREF2. 10kΩ is a good value to start design. 6kΩ to 20kΩ can be chosen. See the D-CAP™ MODE section for more details.
COMP2	15		
RF	3	I/O	Frequency Setting pin. Connect a frequency setting resistor to (Signal) GND. Connect to an external clock for synchronization.
IMON1	11	O	Current monitor outputs for CH1. Adding RC filter is recommended.
VREF2	13	O	2V Reference Output. Bypass to (signal) GND by 0.22 μF ceramic capacitor.
TRIP	14	I	Over current trip level and discharge mode selection pin. GND: V <sub>OCL-ULV</sub> , Discharge on VREF2: V <sub>OCL-ULV</sub> , Discharge off VREG3: V <sub>OCL-LV</sub> , Discharge off VREG5: V <sub>OCL-LV</sub> , Discharge on
EN	12	I	VREF2 and VREG5 Linear Regulators Enable Pin. When turning on, apply greater than 1.2V and less than 6V. Connect to GND to Disable.
VBST1	31	I	Supply inputs for high-side NFET driver (boot strap terminal). Connect a capacitor (0.1μF or greater is recommended) from this pin to respective SW terminal. Additional SB diode from VREG5 to this pin is an optional.
VBST2	26		
DRVL1	30	O	Low-side MOSFET gate driver outputs. Source 1.3Ω, sink 0.7Ω, GND referenced driver.
DRVL2	27		
V5SW	2	I	VREG5 switchover power supply input pin.
VREG5	29	O	5V, 100 mA Low Dropout Linear Regulator Output. Bypass to (power) GND using a 10 μF ceramic capacitor. Runs from VIN supply. Internally connected to VBST and DRVL. Shuts off with EN. Switches over to V5SW when 4.8V or above is provided.
VIN	23	I	Supply Input for 5V and 3.3V Linear Regulator. Typically connected to VBAT.
GND	28	—	Ground



**TYPICAL CHARACTERISTICS**

**VIN SHUTDOWN CURRENT  
vs  
INPUT VOLTAGE**

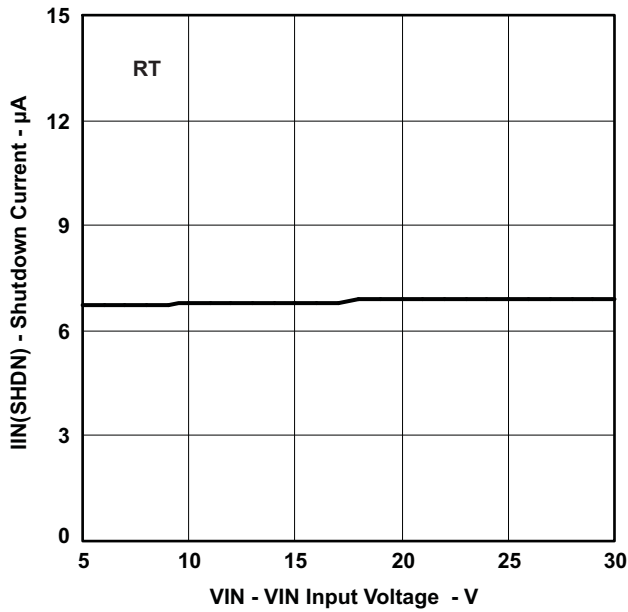

Figure 1.

**VIN SHUTDOWN CURRENT  
vs  
JUNCTION TEMPERATURE**

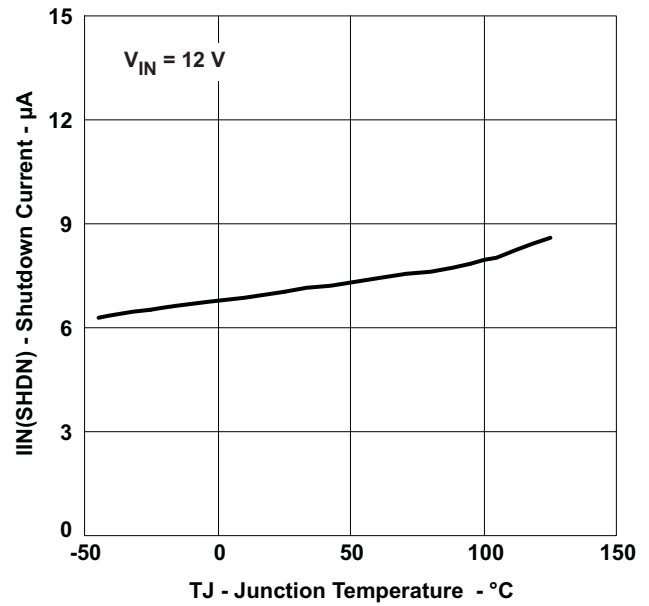

Figure 2.

**VIN STANDBY CURRENT  
vs  
JUNCTION TEMPERATURE**

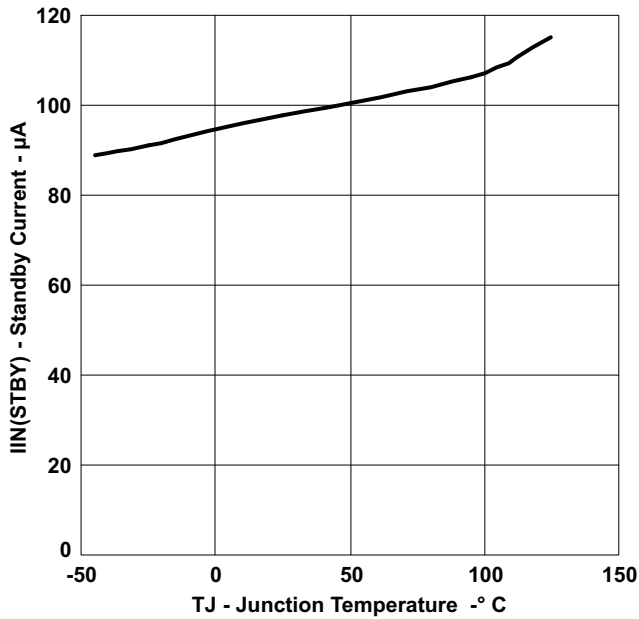

Figure 3.

**VIN STANDBY CURRENT  
vs  
INPUT VOLTAGE**

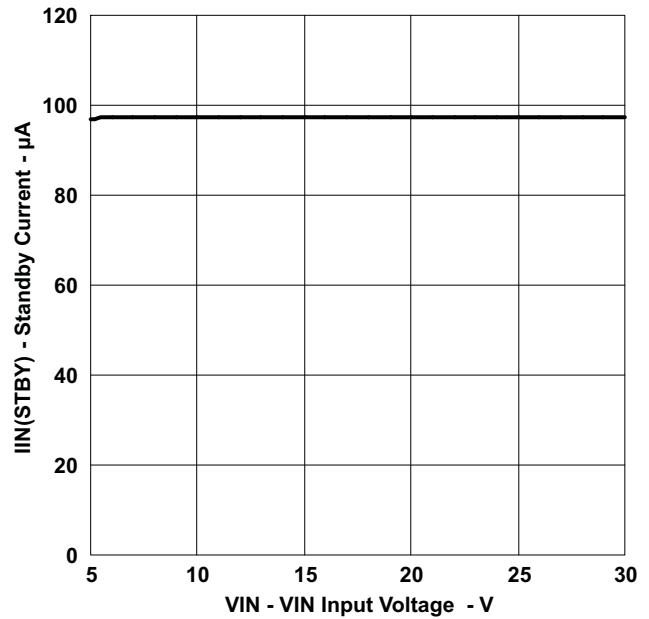

Figure 4.

TYPICAL CHARACTERISTICS (continued)

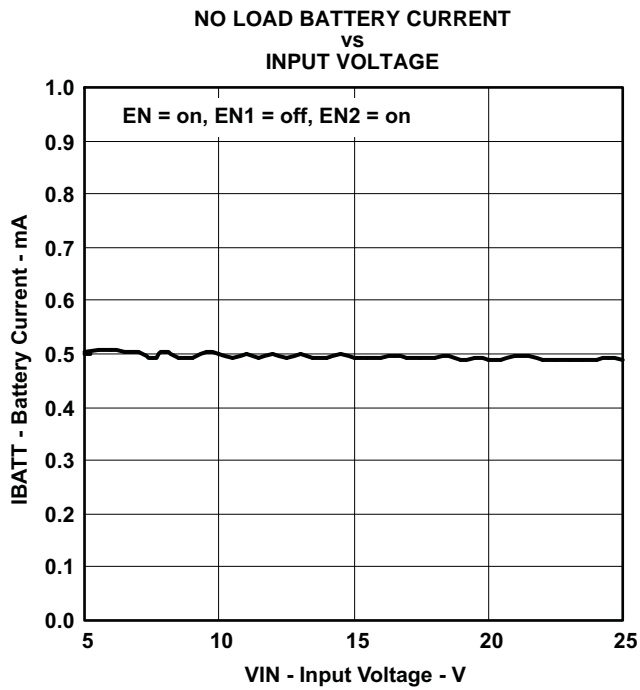

Figure 5.

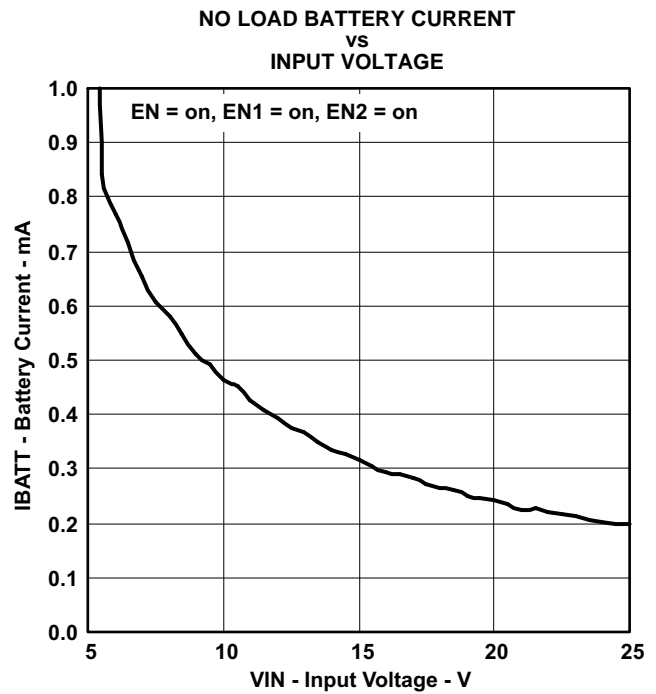

Figure 6.

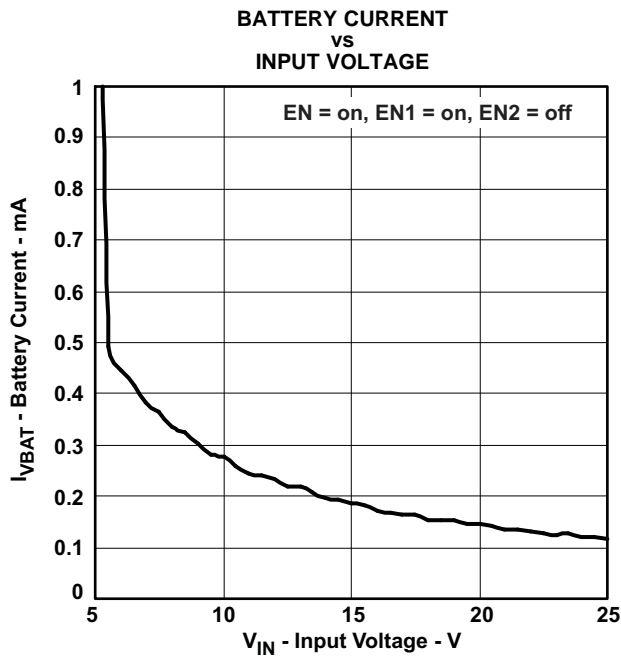

Figure 7.

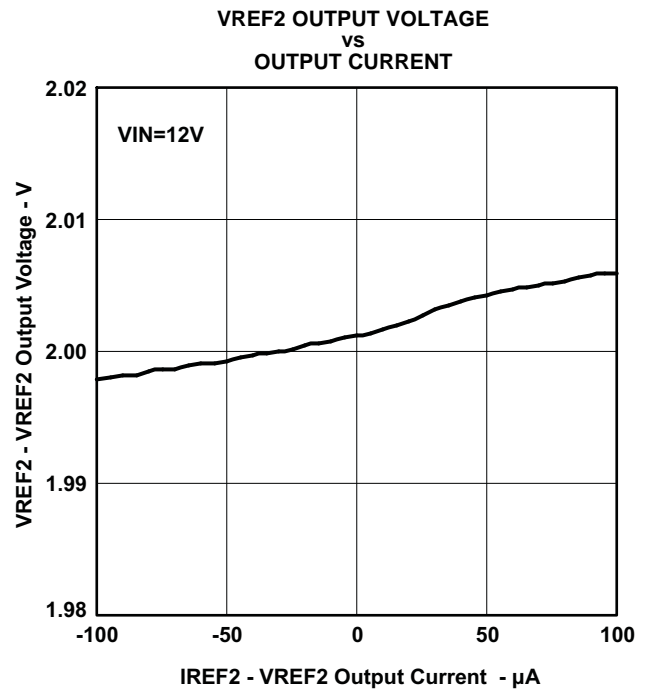

Figure 8.

TYPICAL CHARACTERISTICS (continued)

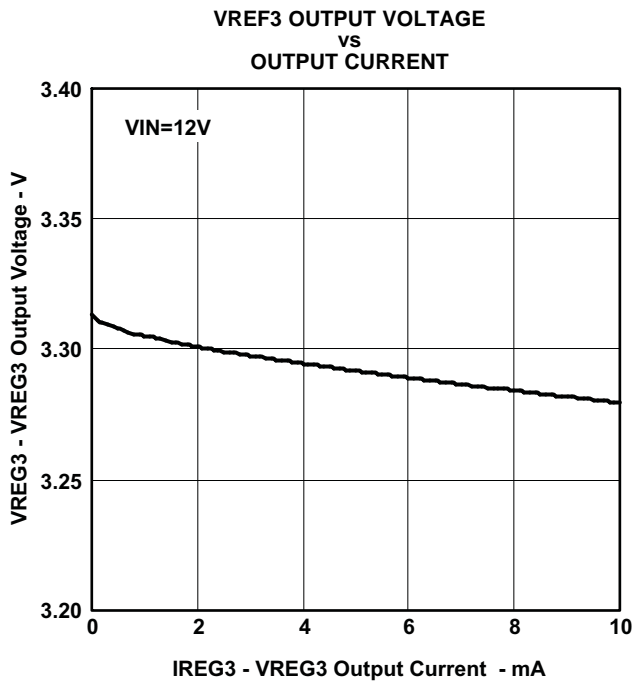

Figure 9.

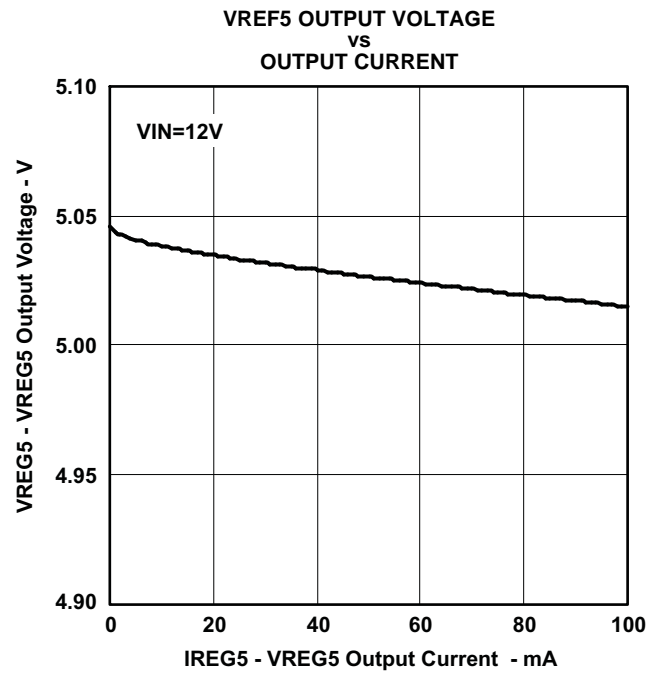

Figure 10.

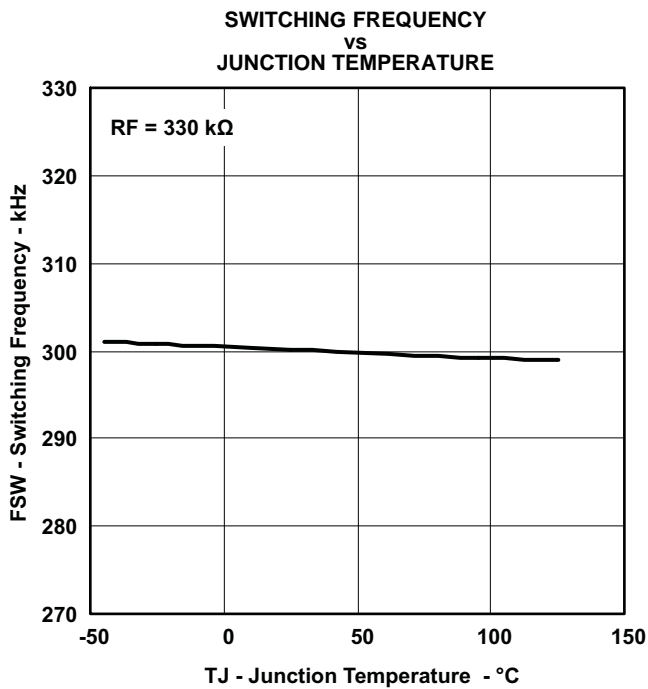

Figure 11.

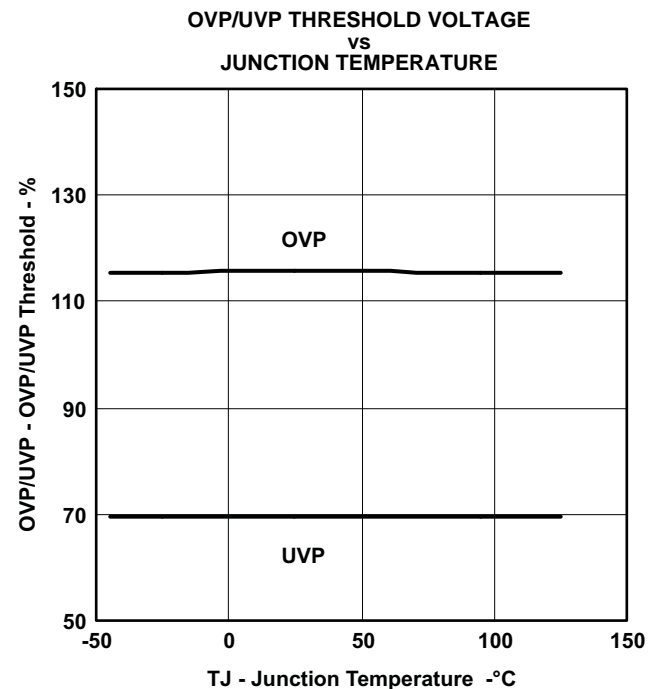

Figure 12.

TYPICAL CHARACTERISTICS (continued)

FORWARD VOLTAGE OF BOOST SW  
vs  
JUNCTION TEMPERATURE

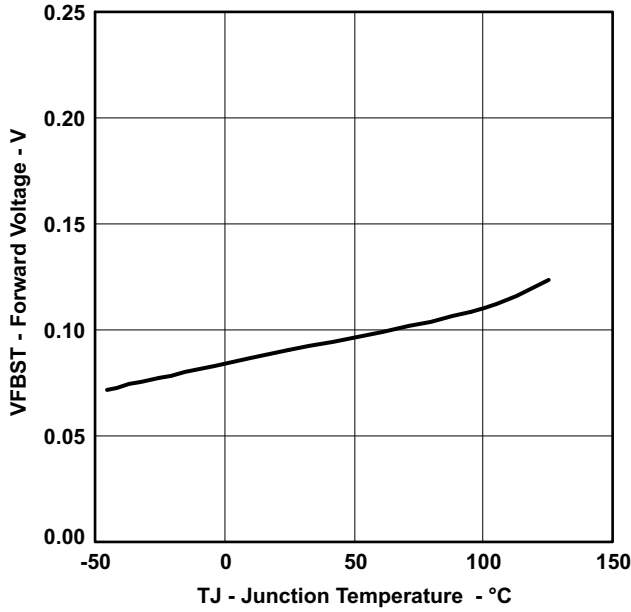

Figure 13.

VBST LEAKAGE CURRENT  
vs  
JUNCTION TEMPERATURE

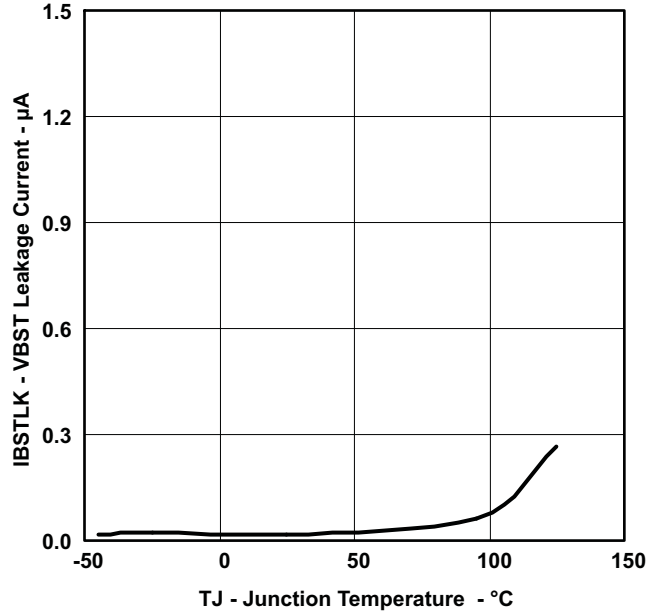

Figure 14.

CURRENT LIMIT THRESHOLD  
vs  
JUNCTION TEMPERATURE

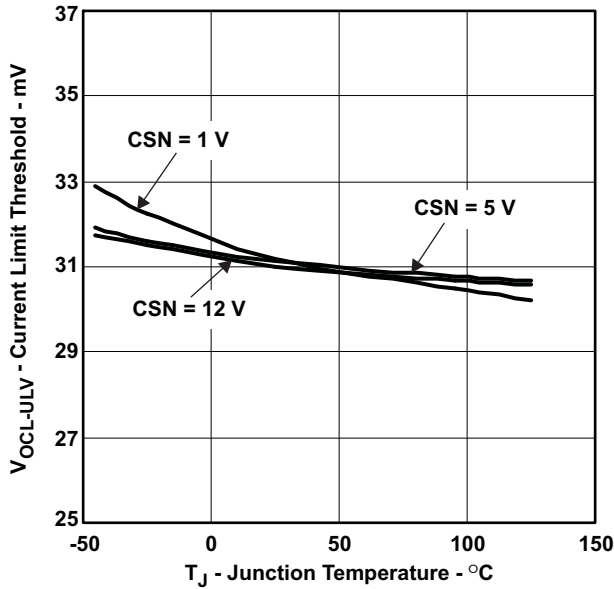

Figure 15.

CURRENT LIMIT THRESHOLD  
vs  
JUNCTION TEMPERATURE

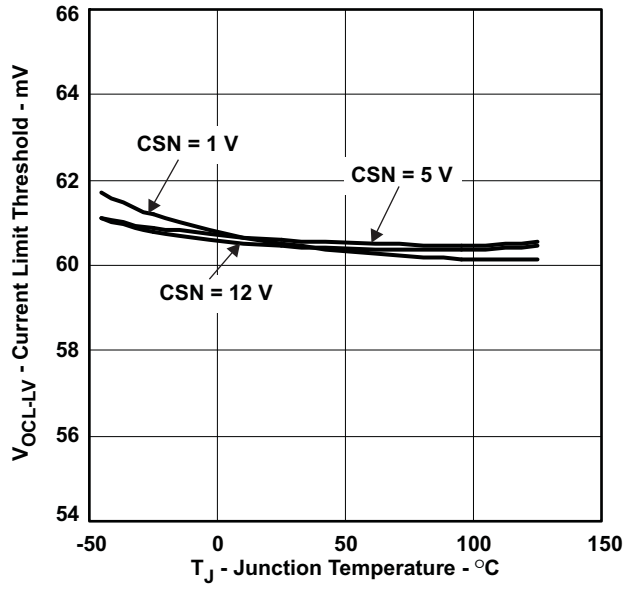

Figure 16.

TYPICAL CHARACTERISTICS (continued)

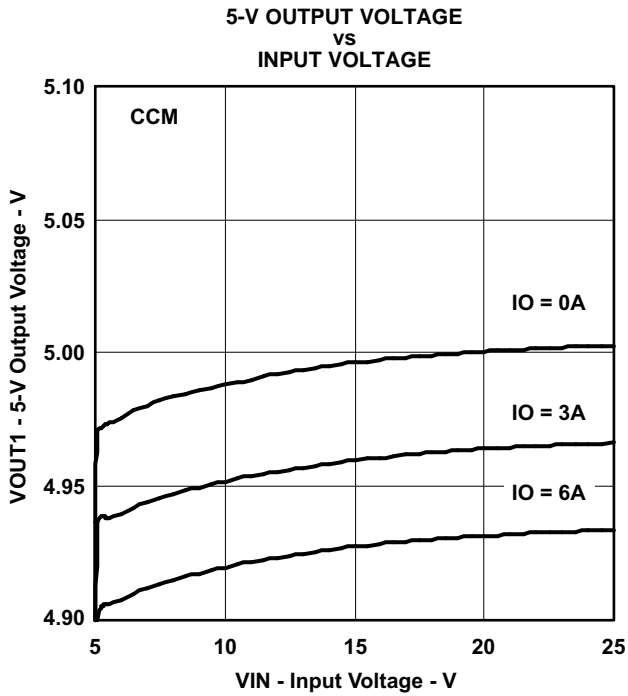

Figure 17.

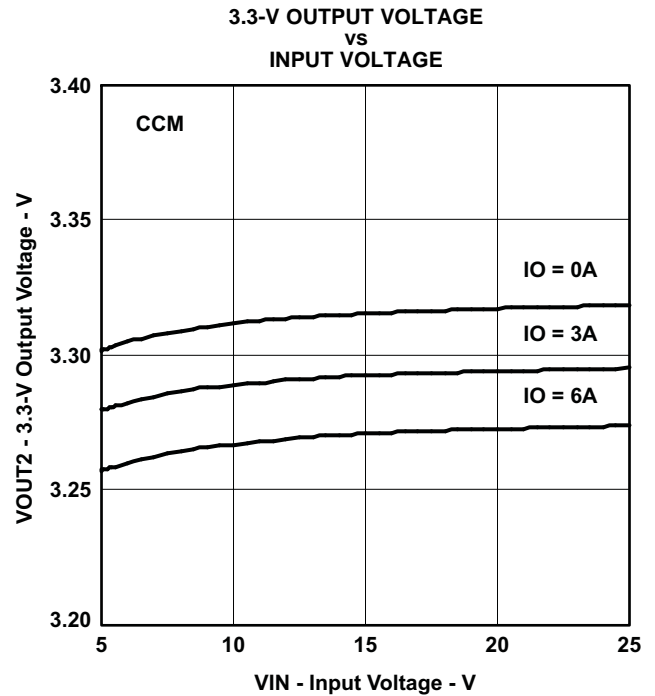

Figure 18.

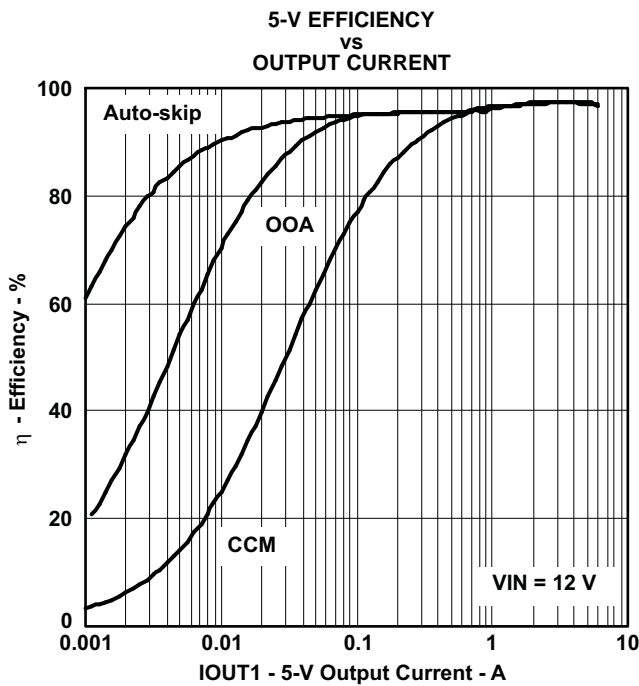

Figure 19.

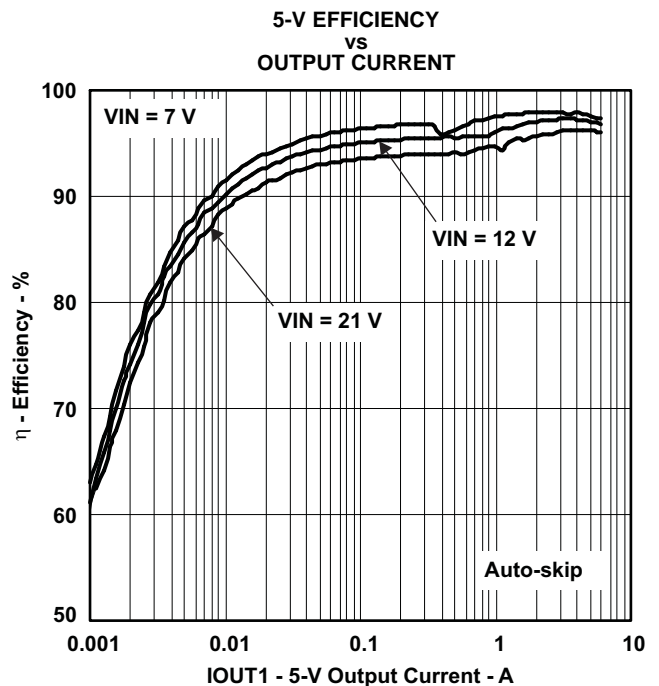

Figure 20.

TYPICAL CHARACTERISTICS (continued)

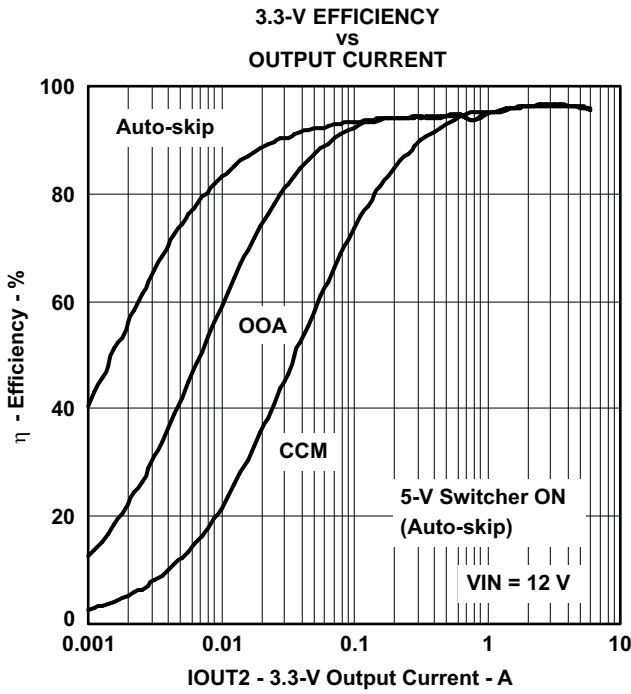

Figure 21.

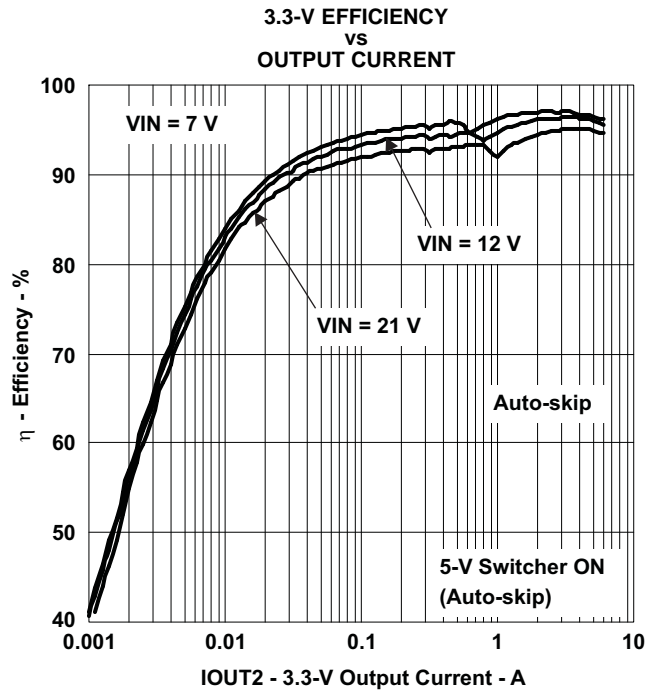

Figure 22.

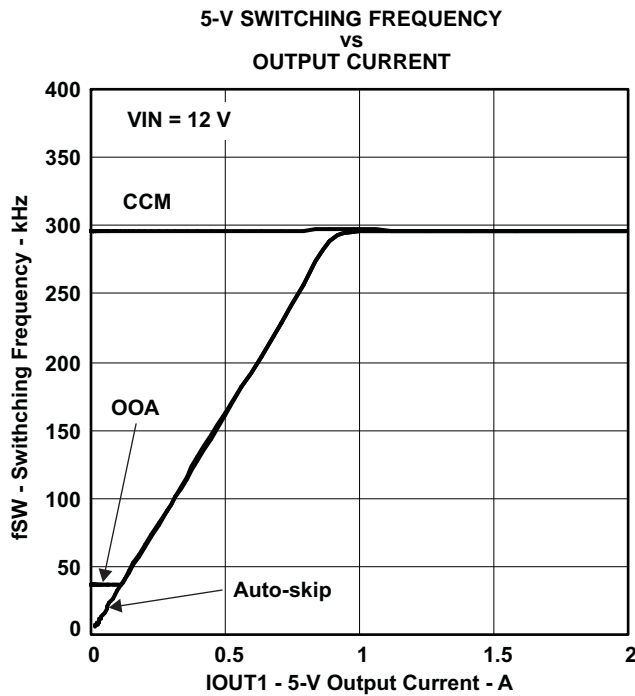

Figure 23.

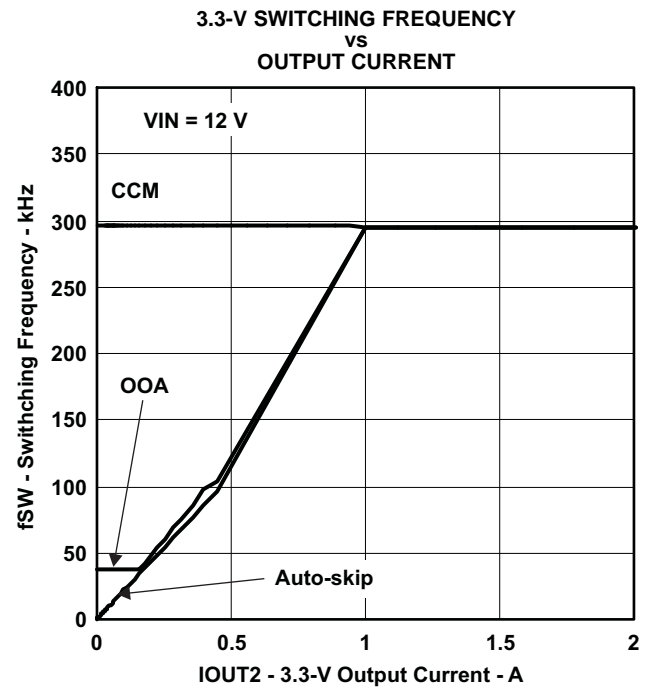

Figure 24.

TYPICAL CHARACTERISTICS (continued)

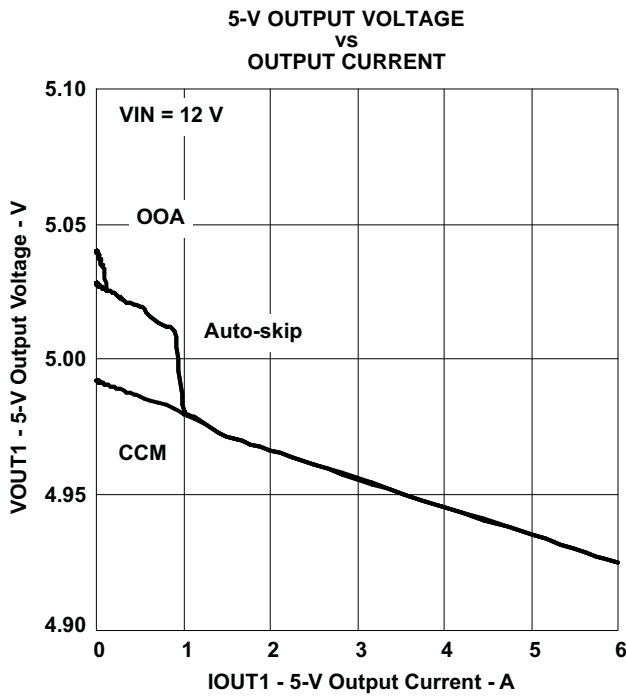

Figure 25.

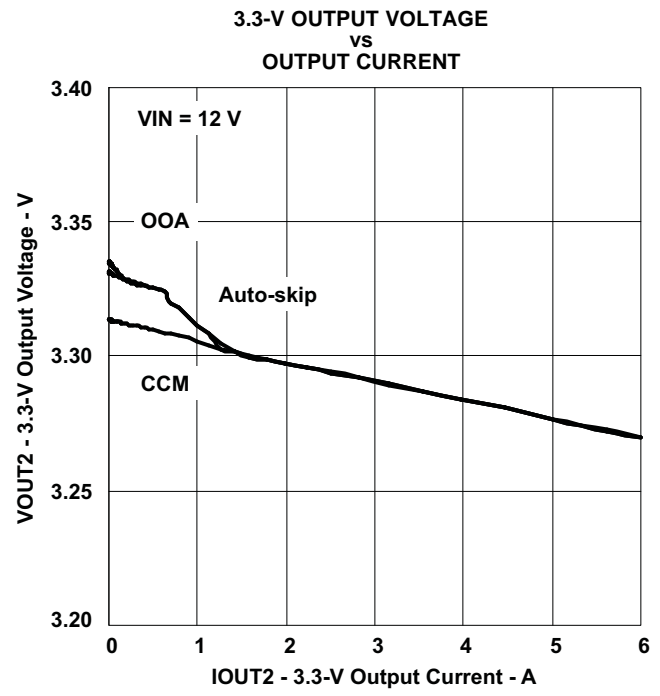

Figure 26.

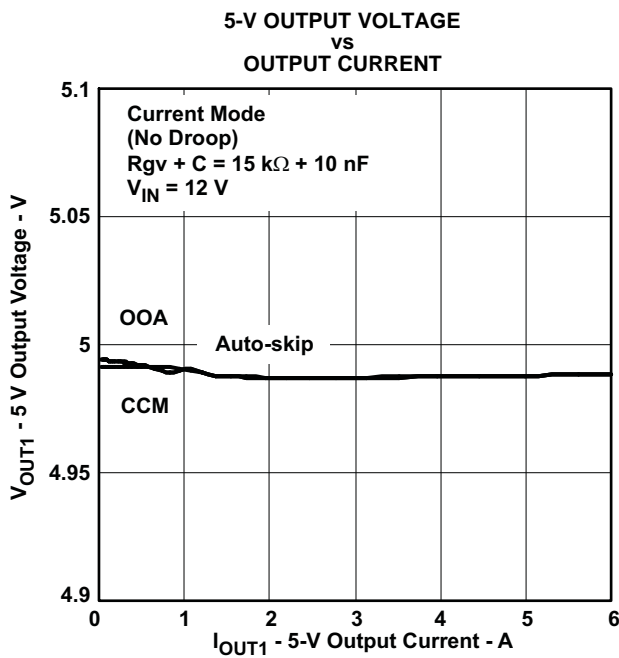

Figure 27.

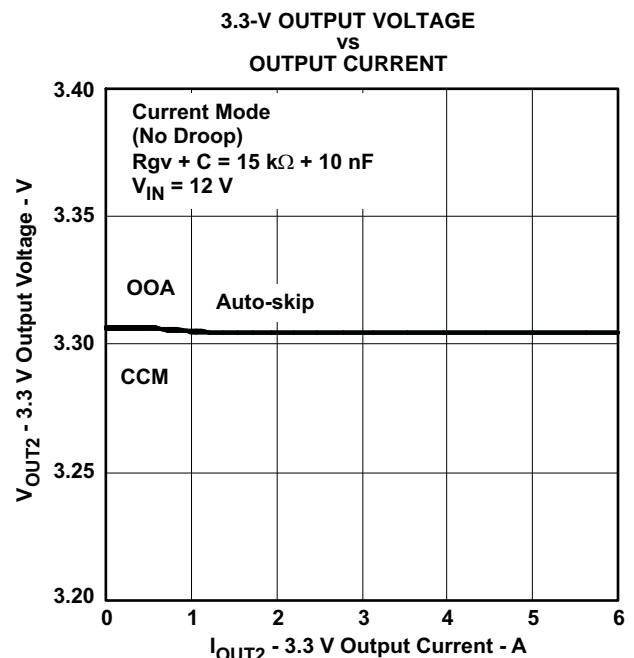
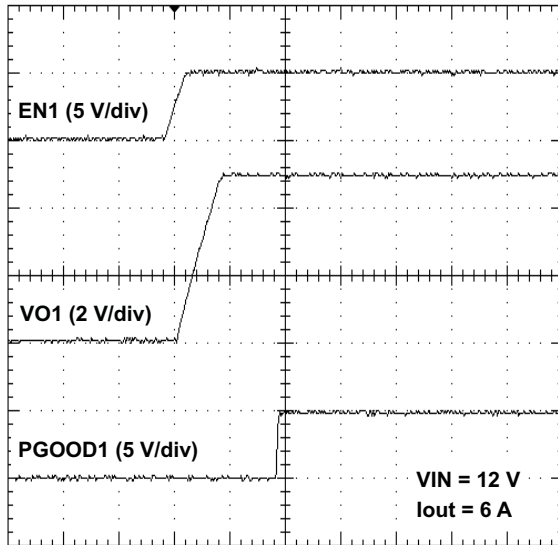

Figure 28.

TYPICAL CHARACTERISTICS (continued)

5.0-V START-UP WAVEFORMS



t - Time - 1 ms/div  
Figure 29.

3.3-V START-UP WAVEFORMS

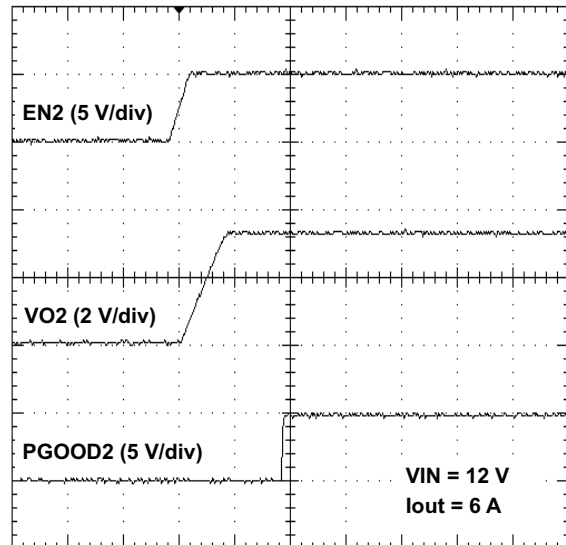

t - Time - 1 ms/div  
Figure 30.

5.0-V SOFT-STOP WAVEFORMS

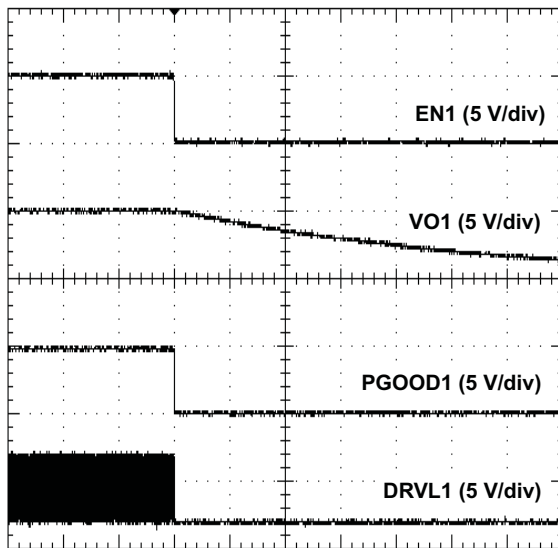

t - Time - 1 ms/div  
Figure 31.

3.3-V SOFT-STOP WAVEFORMS

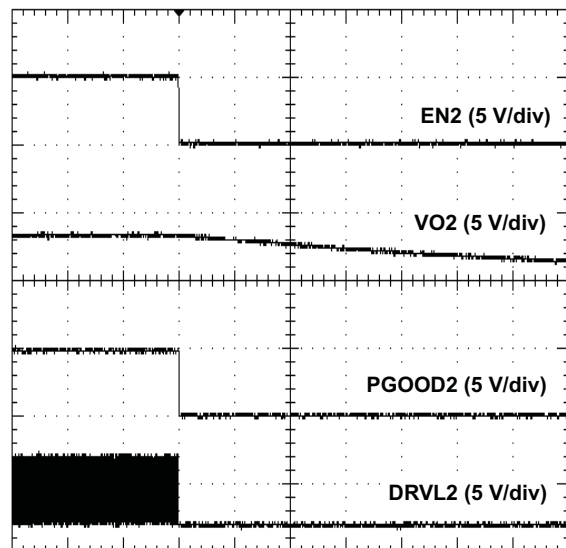

t - Time - 1 ms/div  
Figure 32.



TYPICAL CHARACTERISTICS (continued)

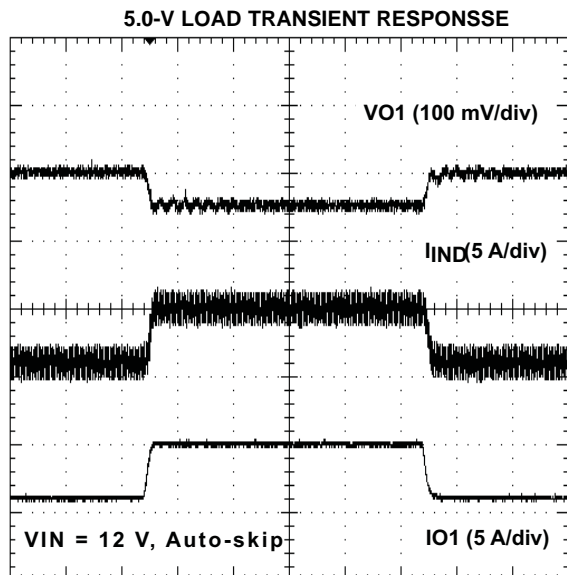

t - Time - 100 ms/div  
Figure 33.

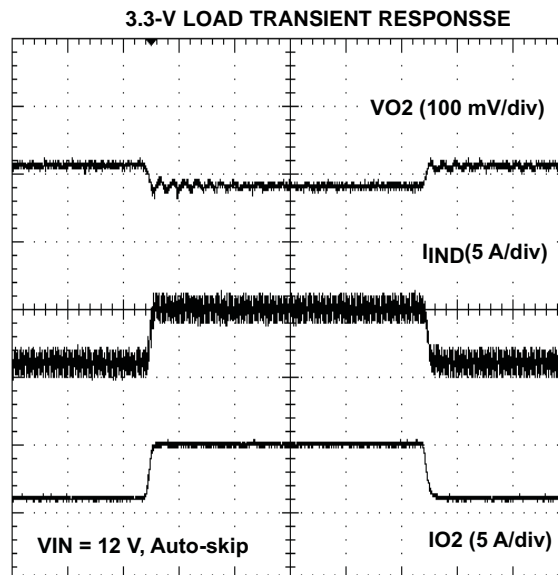

t - Time - 100 ms/div  
Figure 34.

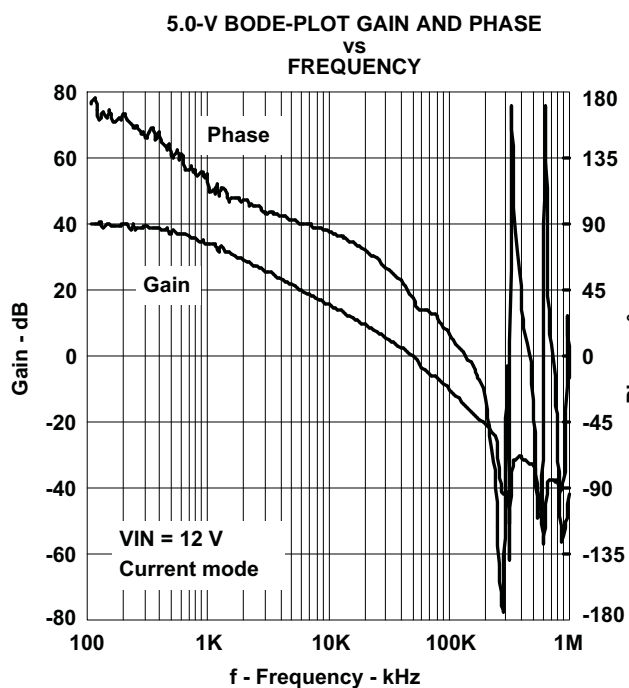

Figure 35.

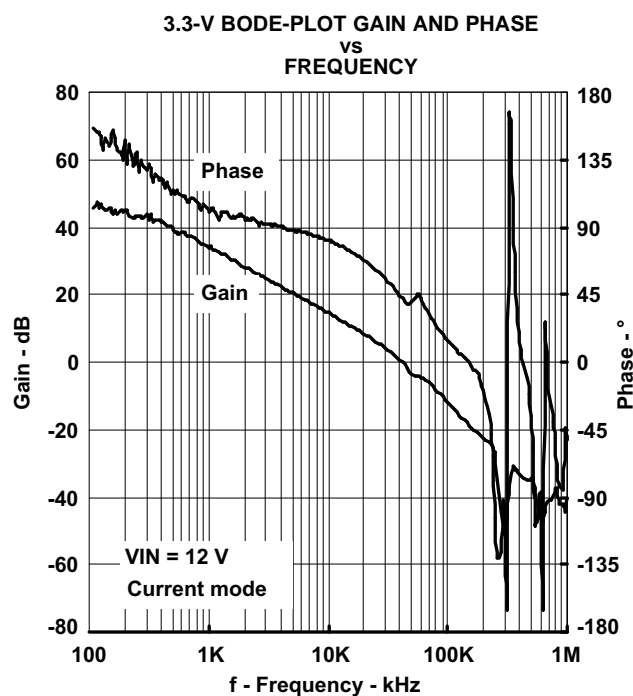

Figure 36.

TYPICAL CHARACTERISTICS (continued)

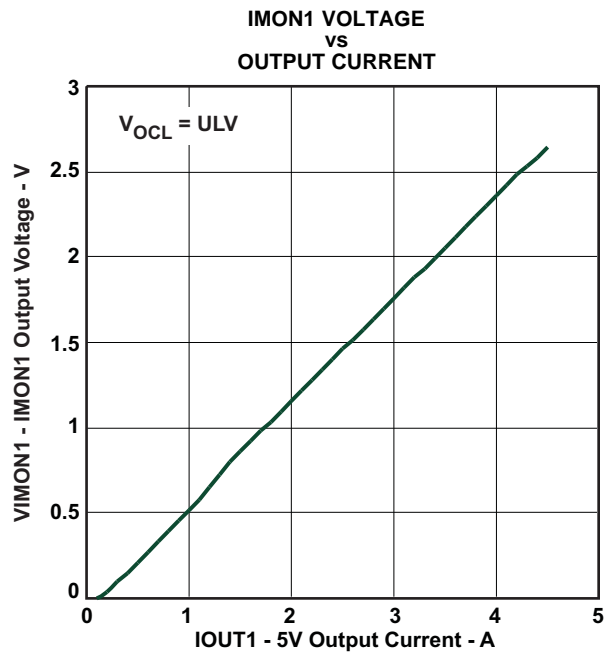

Figure 37.

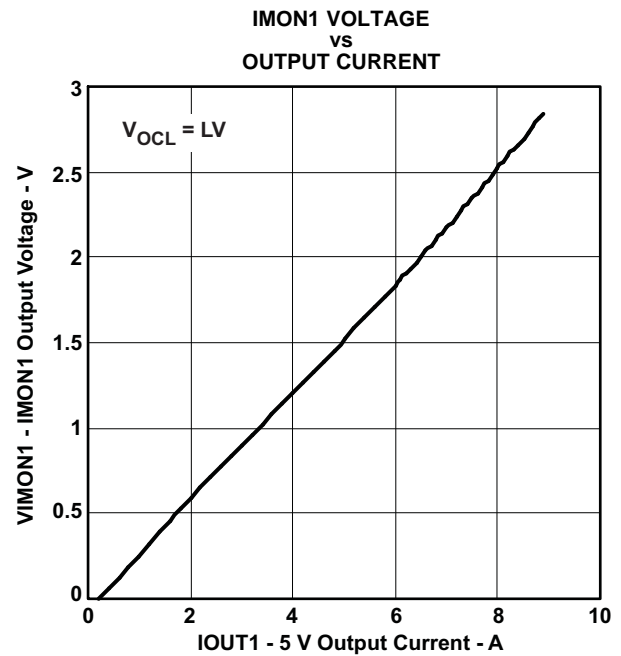
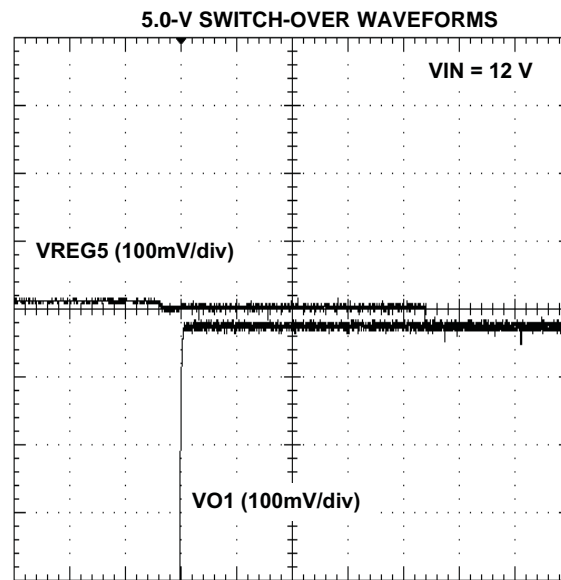

Figure 38.



t - Time - 2 ms/div  
Figure 39.

## DETAILED DESCRIPTION

### ENABLE AND SOFT START

When EN is *Low*, the TPS51221 is in the shutdown state; only the 3.3V LDO stays alive, and consumes 7µA (typically). When EN becomes *High*, the TPS51221 is in the standby state. The 2V reference and the 5V LDO become enable, consume about 80µA with no load condition, and are ready to turn on SMPS channels. Each SMPS channel is turned on when ENx becomes *High*. After ENx is set to high, the TPS51221 begins softstart, and ramps up the output voltage from zero to the target voltage with 0.96 ms. However, if a slower soft-start is required, an external capacitor can be tied from the ENx pin to GND. In this case, the TPS51221 charges the external capacitor with the integrated 2-µA current source. An approximate external soft-start time would be  $t_{EX-SS} = C_{EX} / I_{EN12}$ , it means the time from ENx=1V to ENx=2V. Recommend capacitance is more than 2.2nF.

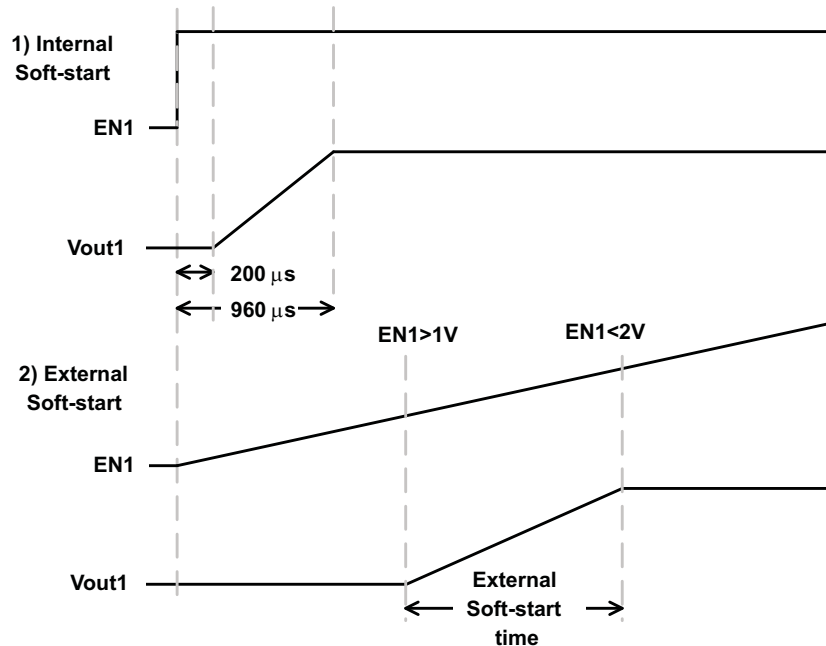

Figure 40. Enable and Soft-Start Timing

Table 1. Enable Logic States

EN	EN1	EN2	VREG3	VREF2	VREG5	CH1	CH2
GND	Don't Care	Don't Care	ON	Off	Off	Off	Off
Hi	Lo	Lo	ON	ON	ON	Off	Off
Hi	Hi	Lo	ON	ON	ON	ON	Off
Hi	Lo	Hi	ON	ON	ON	Off	ON
Hi	Hi	Hi	ON	ON	ON	ON	ON

### 3.3 V, 10 mA LDO (VREG3)

A 3.3-V, 10mA, linear regulator is integrated in the TPS51221. This LDO services some of the analog supply rail for the IC and provides a handy standby supply for 3.3-V *Always On* voltage in the notebook system. Apply a 2.2-µF (at least 1-µF), high quality X5R or X7R ceramic capacitor from VREG3 to (signal) GND, adjacent to the IC.

### 2.0-V, 100 µA Sink/ Source Reference (VREF2)

This voltage is used for the reference of the loop compensation network. Apply a 0.22-µF (at least 0.1-µF), high quality X5R or X7R ceramic capacitor from VREF2 to (signal) GND, adjacent to the IC.

## 5.0-V, 100 mA LDO (VREG5)

A 5.0-V, 100-mA linear regulator is integrated in the TPS51221. This LDO services the main analog supply rail for the IC and provides current for gate drivers until switch-over function becomes enabled. Apply 10- $\mu$ F (at least 4.7- $\mu$ F), high quality X5R or X7R ceramic capacitor from VREG5 to (power) GND, adjacent to the IC.

## VREG5 SWITCHOVER

If the V5SW voltage becomes higher than 4.7V, the internal 5V-LDO is shut off and the VREG5 is shorted to V5SW by an internal MOSFET after a 7.7ms delay. When the V5SW voltage drops lower than 4.5V, the internal switch is turned off and the internal 5V-LDO resumes immediately.

## BASIC PWM OPERATIONS

The main control loop of the SMPS is designed as a fixed-frequency, peak current mode pulse width modulation (PWM) controller. It can achieve stable operation in any type of capacitors, including low ESR capacitor(s) such as ceramic or specialty polymer capacitors.

The TPS51221 SMPS uses the output voltage information and the inductor current information to regulate the output voltage. The output voltage information is sensed by VFBx pin. The signal is compared with the internal 1-V reference and the voltage difference is amplified by a transconductance amplifier (VFB-AMP). The inductor current information is sensed by CSPx and CSNx pins. The voltage difference is amplified by another transconductance amplifier (CS-AMP). The output of the VFB-AMP indicates the target peak inductor current. If the output voltage goes down, the TPS51221 increases the target inductor current to raise the output voltage. On the other hand, if the output voltage goes up the TPS51221 decreases the target inductor current to reduce the output voltage.

At the beginning of each clock cycle, the high-side MOSFET is turned on, or becomes *ON* state. The high-side MOSFET is turned off, or becomes *OFF* state, after the inductor current reaches the target value—which is determined by the combination value of the output of the VFB-AMP and a ramp compensation signal. The ramp compensation signal is used to prevent sub-harmonic oscillation of the inductor current control loop. The high-side MOSFET is turned on again at the next clock cycle. By repeating the operation in this manner, the controller regulates the output voltage. The synchronous low-side or the *rectifying* MOSFET is turned on each *OFF* state to keep the conduction loss minimum.

## PWM FREQUENCY CONTROL

TPS51221 has a fixed frequency control scheme with 180° phase shift. The switching can be determined by an external resistor which is connected between RF pin and GND, and can be calculated using [Equation 1](#):

$$f_{sw}[\text{kHz}] = \frac{1 \times 10^5}{RF[\text{k}\Omega]} \quad (1)$$

The TPS51221 can also synchronize to the external clock, of more than 2.5-V amplitude, by applying the signal to RF pin. The set timing of the channel-1 initiates at the raising edge (1.3V typ) of the clock, and channel-2 initiates at the falling edge (1.1V typ). Therefore, the 50% duty signal makes both channels 180° phase shift.

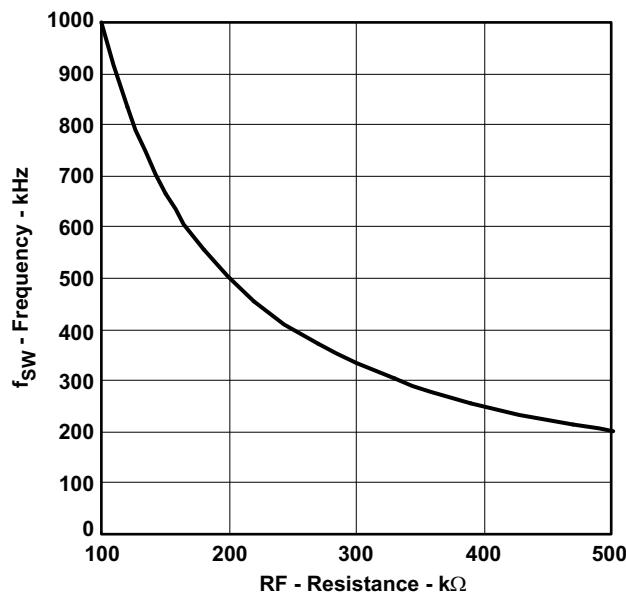

Figure 41. Switching Frequency vs RF

## LIGHT LOAD OPERATION

The TPS51221 automatically reduces switching frequency at light load condition to maintain high efficiency if *Auto Skip* or *OOA* mode is selected by SKIPSELx. This reduction of frequency is achieved by skipping pulses. As the output current decreases from heavy load condition, the inductor current is also reduced and eventually comes to the point that its *peak* touches a predetermined current,  $I_{LL(PEAK)}$ , which indicates the boundary between a heavy load conduction and a light load condition. Once the top MOSFET is turned on, the TPS51221 does not allow turning it off until it touches  $I_{LL(PEAK)}$ . This eventually causes an over-voltage condition to the output, and pulse skipping. From the next pulse after zero-crossing is detected,  $I_{LL(PEAK)}$  is limited by the ramp-down signal which starts from 25% of the over-current limit setting ( $I_{OCL(PEAK)}$ ; see the [CURRENT PROTECTION](#) section) toward 5% of  $I_{OCL(PEAK)}$ , over one switching cycle to prevent causing a large ripple. The transition load point to the light load operation  $I_{LL(DC)}$  can be calculated as follows;

$$I_{LL(DC)} = I_{LL(PEAK)} - 0.5 \times I_{IND(RIPPLE)} \quad (2)$$

$$I_{IND(RIPPLE)} = \frac{1}{L \times f_{SW}} \times \frac{(V_{IN} - V_{OUT}) \times V_{OUT}}{V_{IN}} \quad (3)$$

where  $f_{SW}$  is the PWM switching frequency as determined by RF resistor setting or external clock. Switching frequency versus output current in the light load condition is a function of L, f,  $V_{IN}$  and  $V_{OUT}$ ; but it decreases almost proportional to the output current from the  $I_{LL(DC)}$  given above however, as the switching is synchronized with clock. Due to the synchronization, the switching waveform in boundary load condition (close to  $I_{LL(DC)}$ ), appears as a sub-harmonic oscillation; however, it is the intended operation.

If SKIPSELx is tied to GND, TPS51221 works at the constant frequency of  $f_{SW}$ , regardless of its load current.

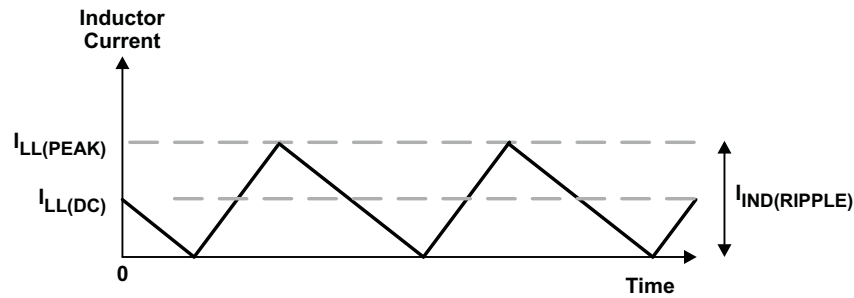

Figure 42. Boundary Between Pulse Skipping and CCM

$$I_{LL(PEAK) Ramp} = \left( 0.25 - 0.2 \times \frac{V_{OUT}}{V_{IN}} \right) \times I_{OCL(PEAK)} \tag{4}$$

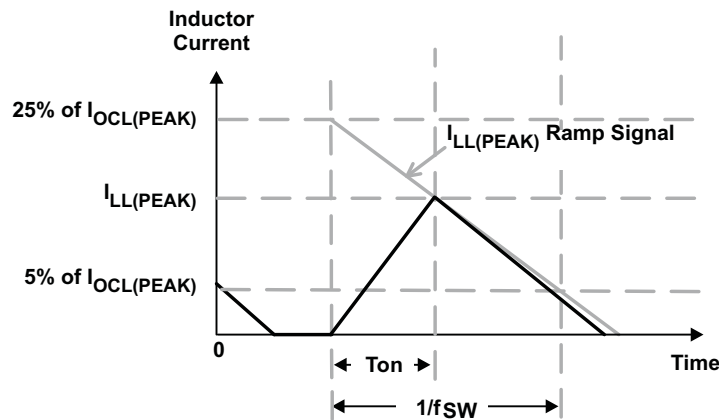

Figure 43. Inductor Current Limit at Pulse Skipping

Table 2. Skip Mode Selection

SKIPSELx	GND	VREF2	VREG3	VREG5
Operating Mode	Continuous Conduction	Auto Skip	OOA Skip (max 7 skips, for <400 kHz)	OOA Skip (max 15 skips, for equal to or greater than 400kHz)

**OUT OF AUDIO SKIP OPERATION**

Out-Of-Audio™ (OOA) light load mode is a unique control feature that keeps the switching frequency above acoustic audible frequencies toward virtually no-load condition while maintaining best-of-the-art high conversion efficiency. When OOA is selected, the switching frequency is kept higher than audible frequency range in any load condition. The TPS51221 automatically reduces the switching frequency at light-load conditions. OOA control circuit monitors the states of both MOSFETs and forces an ON state if a predetermined number of pulses are skipped. This means that the high-side MOSFET is turned on before the output voltage declines down to the target value, so that eventually an over-voltage condition is caused. The OOA control circuit detects this over-voltage condition and begins modulating the skip-mode on-time to keep the output voltage.

The TPS51221 supports a wide switching frequency range; therefore, OOA skip mode has two selections; see Table 2. When 300kHz switching frequency is selected, max 7 skip (SKIPSEL=3.3V) makes lowest frequency at 37.5kHz. If max 15 skip is chosen, it becomes 18.8kHz; hence, max 7 skip is suitable for less than 400kHz, and max 15 skip is for equal to or greater than 400kHz.

## 99% DUTY CYCLE OPERATION

In a low dropout condition such as 5V input to 5V output, the basic control loop tries to keep the high-side MOSFET 100% ON. However, with an N-MOSFET used for the top switch it is not possible to use 100% on-cycle to charge the boot strap capacitor. The TPS51221 detects the 100%-ON condition and inserts the OFF state at the appropriate time.

## HIGH-SIDE DRIVER

The high-side driver is designed to drive high current, low  $r_{DS(on)}$  N-channel MOSFET(s). The drive capability is represented by its internal resistance, which is 1.7  $\Omega$  for VBSTx to DRVHx, and 1.0  $\Omega$  for DRVHx to SWx. When configured as a floating driver, 5V bias voltage is delivered from VREG5 supply. The instantaneous drive current is supplied by the flying capacitor between VBSTx and SWx pins. The average drive current is equal to the gate charge at  $V_{gs}=5V$  times the switching frequency. This gate drive current, as well as the low-side gate drive current times 5V, produces the driving power which needs to be dissipated from the TPS51221 package. A dead time to prevent shoot-through is internally generated between high-side MOSFET off to low-side MOSFET on, and low-side MOSFET off to high-side MOSFET on.

## LOW-SIDE DRIVER

The low-side driver is designed to drive high current low  $R_{DS(on)}$  N-channel MOSFET(s). The drive capability is represented by its internal resistance, which is 1.3 $\Omega$  for VREG5 to DRVLx, and 0.7  $\Omega$  for DRVLx to GND. The 5-V bias voltage is delivered from VREG5 supply. The instantaneous drive current is supplied by an input capacitor connected between VREG5 and GND. The average drive current is also calculated by the gate charge at  $V_{gs}=5V$  times switching frequency.

## CURRENT SENSING SCHEME

In order to provide both good accuracy and cost effective solution, the TPS51221 supports external resistor sensing and inductor DCR sensing. An RC network with high quality X5R or X7R ceramic capacitor should be used to extract voltage drop across DCR. A value of 0.1 $\mu$ F is a good design start. CSPx and CSNx should be connected to positive and negative terminal of the sensing device, respectively. The TPS51221 has an internal current amplifier. The gain of the current amplifier,  $G_c$ , is selected by TRIP terminal. In any setting, the output signal of the current amplifier becomes 100mV at the OCL setting point. This means that the current sensing amplifier normalizes the current information signal based on the OCL setting. Attaching an RC network is recommended even with a resistor sensing scheme to get accurate current sensing; see section [EXTERNAL PARTS SELECTION](#) for detailed configurations.

## CURRENT PROTECTION

The TPS51221 has cycle-by-cycle over-current limiting control. If the inductor current becomes larger than the over-current trip level, TPS51221 turns off the high-side MOSFET, turns on the low-side MOSFET and waits for the next clock cycle.

$I_{OCL(PEAK)}$  sets peak level of the inductor current. Thus, the DC load current at over-current threshold,  $I_{OCL(DC)}$ , can be calculated as follows;

$$I_{OCL(DC)} = I_{OCL(PEAK)} - 0.5 \times I_{IND(RIPPLE)} \quad (5)$$

$$I_{OCL(PEAK)} = \frac{V_{OCL}}{R_{SENSE}} \quad (6)$$

where  $R_{SENSE}$  is resistance of the current-sensing device and  $V_{OCL}$  is the over-current trip threshold voltage, as determined by TRIP pin voltages. This is shown in [Table 3](#).

In an over-current condition, the current to the load exceeds the current to the output capacitor; thus, the output voltage tends to fall down and ends up crossing the under-voltage protection threshold, resulting in shutdown.

**Table 3. OCL Trip and Discharge Selection**

TRIP	GND	VREF2	VREG3	VREG5
$V_{OCL}$ (OCL Trip voltage)	$V_{OCL-ULV}$ (Ultra Low Voltage)		$V_{OCL-LV}$ (Low Voltage)	
Discharge	Enable	Disable	Disable	Enable

## POWER GOOD

The TPS51221 has a power-good output for both switcher channels. The power-good function is activated after softstart has finished. If the output voltage comes within  $\pm 5\%$  of the target value, internal comparators detect power-good state and the power-good signal becomes high after 1ms internal delay. If the output voltage goes outside of  $\pm 10\%$  of the target value, the power-good signal becomes low after 1.5 $\mu$ s internal delay. Voltage applied should be less than 6V and the recommended pull-up resistance value is from 100k $\Omega$  to 1M $\Omega$ .

## OUTPUT DISCHARGE CONTROL

The TPS51221 discharges output when ENx is low. The TPS51221 discharges outputs using an internal MOSFET connected to CSNx and GND. The current capability of these MOSFETs is limited to discharge the output capacitor slowly. If ENx becomes high during discharge, the MOSFETs are turning on, and some output voltage remains. SMPS changes over to soft-start. PWM will begin after the target voltage overtakes the remaining output voltage. This function can be disabled as shown in [Table 3](#).

## CURRENT MONITOR

The TPS51221 monitors the output current as the voltage difference between CSPx and CSNx terminal. The transconductance amplifier (CS-AMP) amplifies this differential voltage 100 times when  $V_{OCL}$  is set  $V_{OCL\_ULV}$ , 50 times when  $V_{OCL}$  is set  $V_{OCL\_LV}$ , and sends out from IMON1 thermal. This function is only for the channel 1 output and adding an RC filter is recommended.

## OVER/UNDER VOLTAGE PROTECTION

The TPS51221 monitors the output voltage to detect over- and under-voltage. When the output voltage becomes 15% higher than the target value, the OVP comparator output goes high, and the circuit latches the high-side MOSFET driver OFF and the low-side MOSFET driver ON, and shuts off another channel.

When the feedback voltage becomes lower than 70% of the target voltage, the UVP comparator output goes high and an internal UVP delay counter begins counting. After 1ms, the TPS51221 latches OFF both high-side and low-side MOSFETs, and shuts off another channel. This UVP function is enabled after soft start has completed. The procedures for restarting from these protection states are:

- (1) toggle EN,
- (2) toggle EN1 and EN2 or
- (3) once be hit UVLO

## UVLO PROTECTION

TPS51221 has under-voltage lock out protection (UVLO) for VREG5, VREG3 and VREF2. When the voltage is lower than UVLO threshold voltage, the TPS51221 shuts off each output as shown in [Table 4](#). This is non-latch protection.

**Table 4. UVLO Protection**

	CH1/ CH2	VREG5	VREG3	VREF2
VREG5 UVLO	Off	—	On	On
VREG3 UVLO	Off	Off	—	Off
VREF2 UVLO	Off	Off	On	—

## THERMAL SHUTDOWN

TPS51221 monitors the temperature of itself. If the temperature exceeds the threshold value TPS51221 shuts off both SMPS, 5V-LDO and decreases VREG3 current limitation to 5 mA (typically). This is non-latch protection.



## APPLICATION INFORMATION

### EXTERNAL PARTS SELECTION

A buck converter using TPS51221 consists of linear circuits and a switching modulator. Figure 44 shows basic scheme.

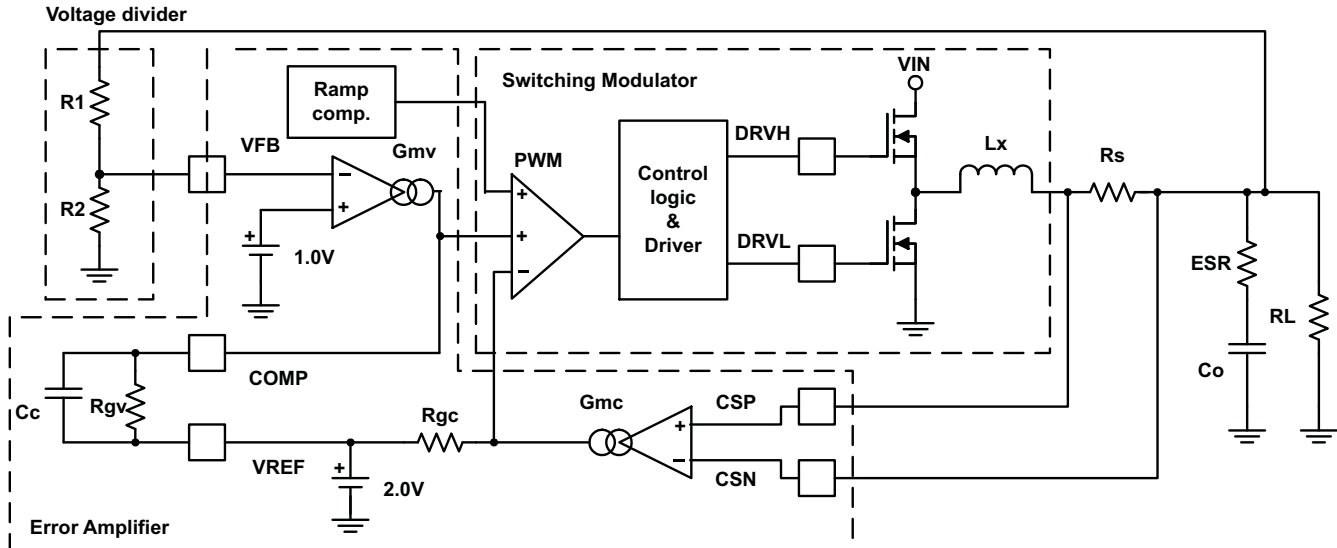

Figure 44. Simplified Current Mode Functional Blocks

The external components can be selected by following manner.

1. Determine output voltage dividing resistors (R1 and R2: shown in Figure 44) using the next equation

$$R1 = (V_{OUT} - 1.0) \times R2 \quad (7)$$

2. **Determine switching frequency.** Higher frequency allows smaller output capacitances; however, efficiency is degraded due to increase of switching loss. Frequency setting resistor for RF-pin can be calculated by;

$$RF[k\Omega] = \frac{1 \times 10^5}{f_{sw} [kHz]} \quad (8)$$

3. **Choose the inductor.** The inductance value should be determined to give the ripple current of approximately 25% to 50% of maximum output current. Recommended ripple current rate is about 30% to 40% at the typical input voltage condition. The next equation uses 33%.

$$L = \frac{1}{0.33 \times I_{OUT(MAX)} \times f_{SW}} \times \frac{(V_{IN(TYP)} - V_{OUT}) \times V_{OUT}}{V_{IN(TYP)}} \quad (9)$$

The inductor also needs to have low DCR to achieve good efficiency, as well as enough room above peak inductor current before saturation.

4. **Determine the OCL trip voltage threshold,  $V_{OCL}$ , and select the sensing resistor.** The OCL trip voltage threshold is determined by TRIP pin setting. Using a smaller value improves S/N ratio. Determine the sensing resistor using next equation.  $I_{OCL(PEAK)}$  should be approximately  $1.5 \times I_{OUT(MAX)}$  to  $1.7 \times I_{OUT(MAX)}$ .

$$R_{SENSE} = \frac{V_{OCL}}{I_{OCL(PEAK)}} \quad (10)$$

5. **Determine Rgv.** Rgv should be determined from preferable droop compensation value and is given by the next equation, based on the typical number of Gmv=500µs.

$$R_{gv} = 0.1 \times \frac{I_{OUT(MAX)}}{I_{OCL(PEAK)}} \times V_{OUT} \times \frac{1}{G_{mv} \times V_{droop}} \quad (11)$$

$$R_{gv}[k\Omega] = 200 \times \frac{I_{OUT(MAX)}}{I_{OCL(PEAK)}} \times \frac{V_{OUT}[V]}{V_{droop}[mV]} \quad (12)$$

If no droop is preferred, attach a series RC network circuit instead of a single resistor. Series resistance is determined to meet the Equation 13. Series capacitance can be arbitrarily chosen to meet the RC time constant but should be kept under 1/10 of  $f_o$ .

6. Determine output capacitance  $C_o$  to achieve stable operation using the next equation. The 0 dB frequency;  $f_o$  should be kept under 1/3 of the switching frequency.

$$f_o = \frac{5}{\pi} \times I_{OCL(PEAK)} \times \frac{1}{V_{OUT}} \times \frac{G_{mv} \times R_{gv}}{C_o} < \frac{f_{sw}}{3} \quad (13)$$

$$C_o > \frac{15}{\pi} \times I_{OCL(PEAK)} \times \frac{1}{V_{OUT}} \times \frac{G_{mv} \times R_{gv}}{f_{sw}} \quad (14)$$

7. **Calculate Cc.** Purpose of this capacitance is to cancel zero caused by ESR of the output capacitor. When using ceramic capacitor(s), there is no need for Cc. If a combination of different capacitors are used, attaching an RC network circuit might be needed instead of single capacitance to cancel zeros and poles caused by the output capacitors. In the case of a single capacitance, Cc is given in Equation 15.

$$C_c = C_o \times \frac{ESR}{R_{gv}} \quad (15)$$

8. **Choose MOSFETs.** Generally, the on resistance strongly affects efficiency at high load conditions as a conduction loss. In case of low output voltage application, the duty ratio is not so high so that the on resistance of high-side MOSFET does not greatly affect efficiency. However, switching speed ( $T_r$  and  $T_f$ ) affects efficiency as a switching loss. As for low-side MOSFET, usually switching loss is not a main portion of the total loss.

## RESISTOR CURRENT SENSING

For more accurate current sensing with an external resistor, the following technique is recommended. Adding RC filtering to cancel the parasitic inductance of the resistor; this filter value can be calculated using Equation 16.

$$C_x \times R_x = \frac{L_x}{R_s} \quad (16)$$

This equation means the time-constant of  $C_x$  and  $R_x$  should match the one of  $L_x$  (ESL) and  $R_s$ .

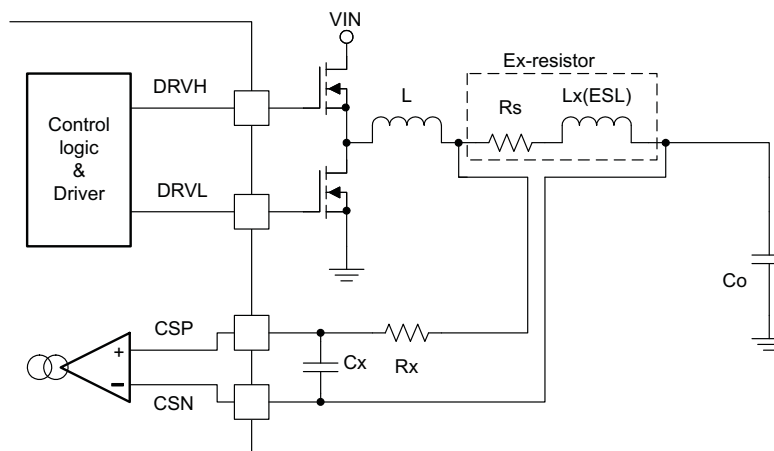

Figure 45. External Resistor Current Sensing

## INDUCTOR DCR CURRENT SENSING

To use an inductor DCR as current sensing resistor ( $R_s$ ), the configuration needs to change, as shown in Figure 46. However, the equation must be satisfied the same as the one using resistor sensing.

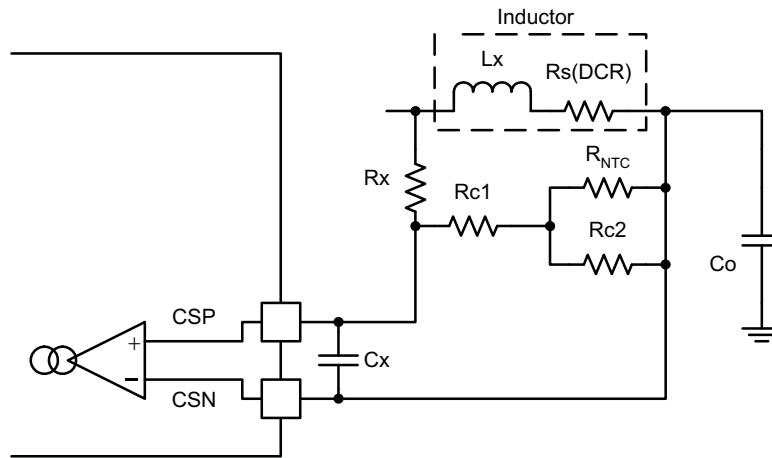

Figure 46. Inductor DCR Current Sensing

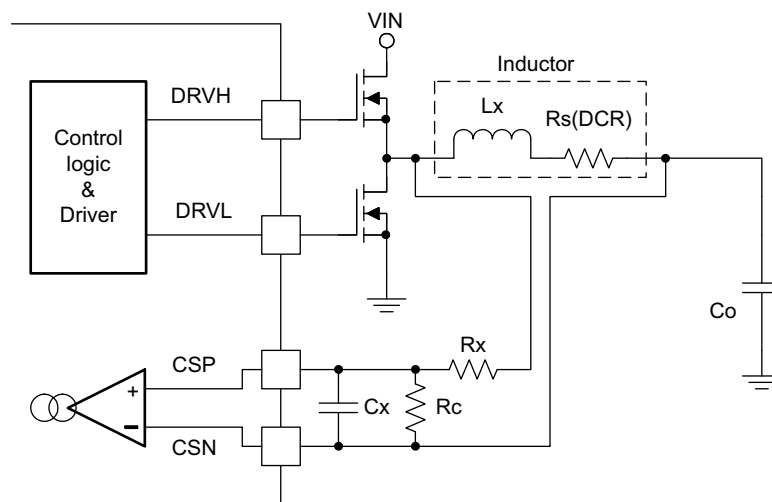

Figure 47. Inductor DCR Current Sensing With Voltage Divider

The TPS51221 has a fixed  $V_{OCL}$  point (60 mV or 30 mV). In order to adjust for DCR, a voltage divider can be configured as shown in Figure 47.

For  $R_x$ ,  $R_c$  and  $C_x$  can be determined as below, and over-current limitation value can be calculated as follows.

$$C_x \times (R_x // R_c) = \frac{L_x}{R_s} \quad (17)$$

$$I_{OCL(PEAK)} = V_{OCL} \times \frac{1}{R_s} \times \frac{R_x + R_c}{R_c} \quad (18)$$

Figure 52 shows the compensation technique for the temperature drifts of the inductor DCR value. This scheme assumes the temperature rise at the thermistor ( $R_{NTC}$ ) is directly proportional to the temperature rise at the inductor.

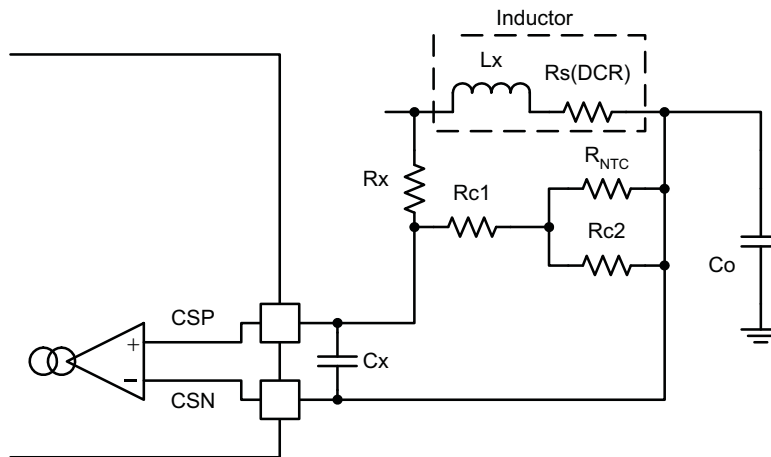

Figure 48. Inductor DCR Current Sensing With Temperature Compensation

**LAYOUT CONSIDERATIONS**

Certain points must be considered before starting a PCB layout work using the TPS51221.

Placement

- Place RC filters for CSP1 and CSP2 close to the IC pins.
- Place bypass capacitors for VREG5, VREG3 and VREF2 close to the IC pins.
- Place frequency-setting resistor close to the IC pin.
- Place the compensation circuits for COMP1 and COMP2 close to the IC pins.
- Place the voltage setting resistors close to the IC pins.

Routing (sensitive analog portion)

- Use separate traces for: (see Figure 49)
  - Output voltage sensing from current sensing (negative-side)
  - Output voltage sensing from V5SW input (when Vout=5V)
  - Current sensing (positive-side) from switch-node

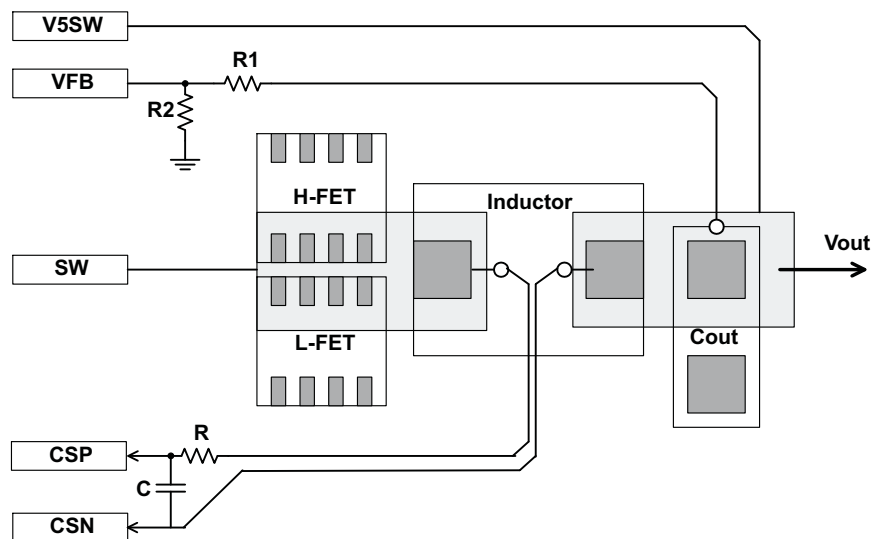
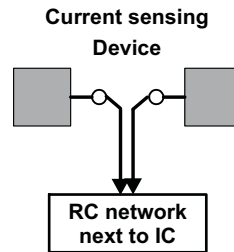

Figure 49. Sensing Trace Routings

- Use Kelvin sensing traces from the solder pads of the current sensing device (inductor or resistor) to current

sensing comparator inputs (CSPx and CSNx). (see [Figure 50](#))

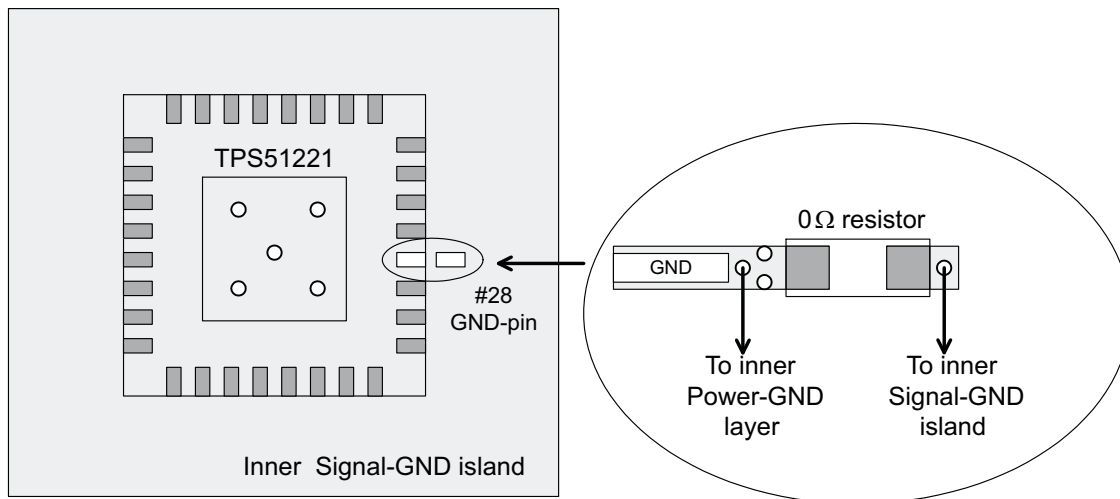

**Figure 50. Current Sensing Traces**

- Use small copper space for VFBx, in other words short and narrow traces to avoid noise coupling
- Connect VFB resistor trace to the positive node of the output capacitor.
- Use signal GND for VREF2 and VREG3 capacitors, RF and VFB resistors and the other sensitive analog components. Placing signal GND island (underneath the IC and fully covered peripheral components) on the internal layer for shielding purpose is recommended. (See [Figure 51](#))
- Use thermal land for PowerPAD™. Five or more vias with 0.33-mm (13-mils) diameter connected from the thermal land to the internal GND plane should be used to help dissipation. Do NOT connect GND-pin to this thermal land on the surface layer, underneath the package.

Routing (power portion)

- Use wider/ shorter traces of DRVL for low-side gate drivers to reduce stray inductance.
- Use the parallel traces of SW and DRVH for high-side MOSFET gate drive and keep them away from DRVL.
- Connect SW trace to source terminal of the high-side MOSFET.
- Use power GND for VREG5, VIN and Vout capacitors and low-side MOSFETs. Power GND and signal GND should be connected near the IC GND terminal. (See [Figure 51](#))



**Figure 51. GND Layout Example**

APPLICATION CIRCUITS

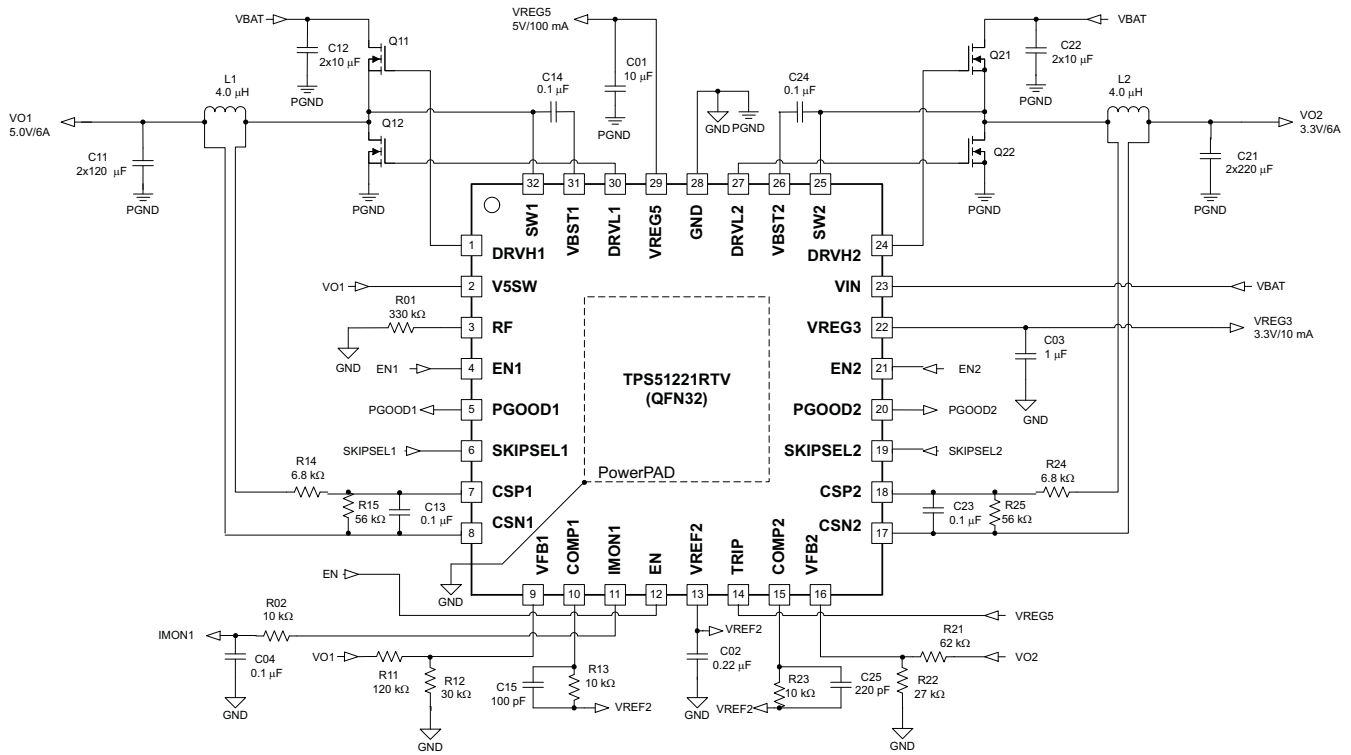

Figure 52. Current Mode, DCR Sensing, 5.0V/5A, 3.3V/5A, 300-kHz

Table 5. Current Mode, DCR Sensing, 5.0V/5A, 3.3V/5A, 300-kHz

SYMBOL	SPECIFICATION	MANUFACTURER	PART NUMBER
C11	2 × 120 μF/ 6.3 V/15-mΩ	Panasonic	EEFCX0J121R
C12	2 × 10 μF/ 25 V	Murata	GRM32DR71E106K
C21	2 × 220 μF/ 4.0 V/15-mΩ	Panasonic	EEFCX0G221R
C22	2 × 10 μF/ 25 V	Murata	GRM32DR71E106K
L1	4.0 μH, 10.3 A, 6.6-mΩ	Sumida	CEP125-4R0MC-H
L2	4.0 μH, 10.3A, 6.6-mΩ	Sumida	CEP125-4R0MC-H
Q11, Q21	30-V, 13.6-A, 9.5-mΩ	IR	IRF7821
Q12, Q22	30-V, 13.8-A, 5.8-mΩ	IR	IRF8113

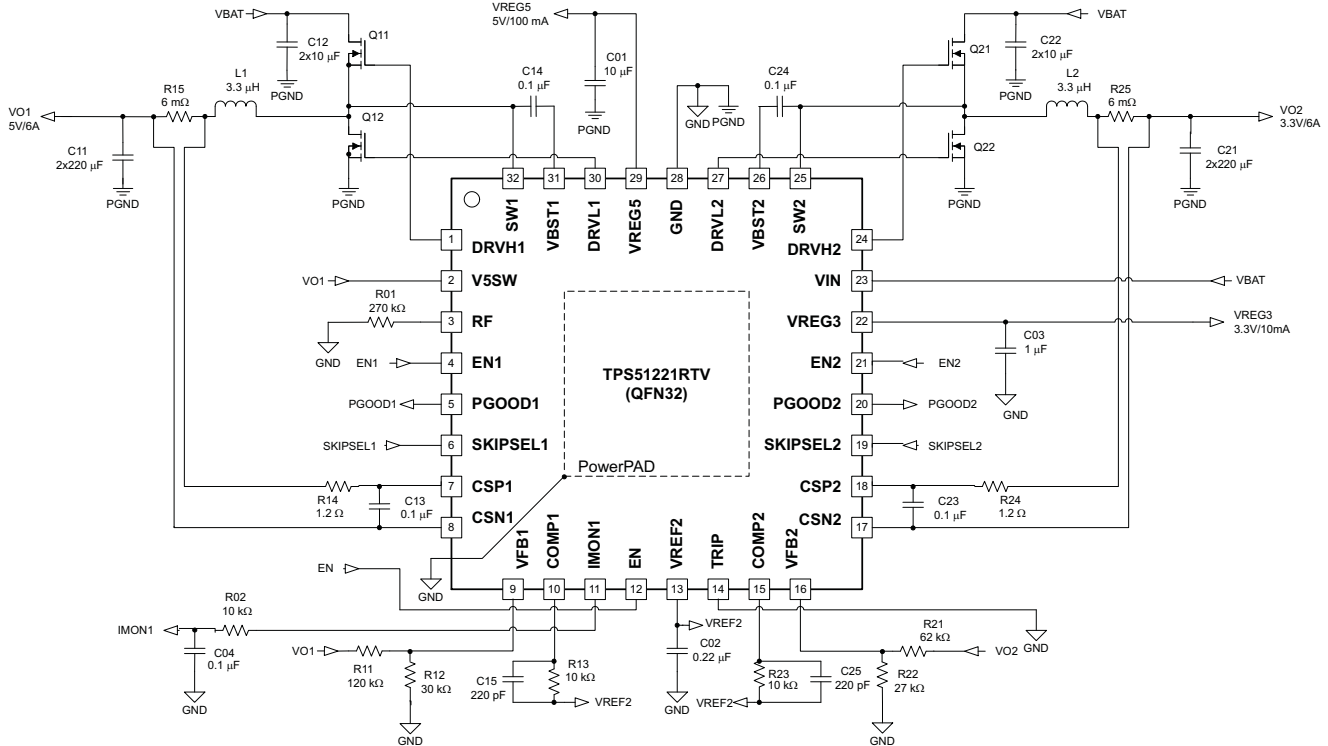

Figure 53. Current Mode, Ex-Resistor Sensing, 5.0V/5A, 3.3V/5A, 370-kHz

Table 6. Current Mode, DCR sensing, 5.0V/5A, 3.3V/5A, 370-kHz

SYMBOL	SPECIFICATION	MANUFACTURER	PART NUMBER
C11	2 x 220 $\mu$ F/ 6.3 V/12-m $\Omega$	Panasonic	EEFUE0J221R
C12	2 x 10 $\mu$ F/ 25 V	Murata	GRM32DR71E106K
C21	2 x 220 $\mu$ F/ 4.0 V/12-m $\Omega$	Panasonic	EEFUE0G221R
C22	2 x 10 $\mu$ F/ 25 V	Murata	GRM32DR71E106K
L1	3.3 $\mu$ H, 10.3 A, 5.9-m $\Omega$	TOKO	FDA1055-3R3M
L2	3.3 $\mu$ H, 10.3 A, 5.9-m $\Omega$	TOKO	FDA1055-3R3M
Q11, Q21	30-V, 13.6-A, 9.5-m $\Omega$	IR	IRF7821
Q12, Q22	30-V, 13.8-A, 5.8-m $\Omega$	IR	IRF8113

**PACKAGING INFORMATION**

Orderable Device	Status <sup>(1)</sup>	Package Type	Package Drawing	Pins	Package Qty	Eco Plan <sup>(2)</sup>	Lead/Ball Finish	MSL Peak Temp <sup>(3)</sup>
TPS51221RTVR	ACTIVE	QFN	RTV	32	3000	Green (RoHS & no Sb/Br)	CU NIPDAU	Level-2-260C-1 YEAR
TPS51221RTVRG4	ACTIVE	QFN	RTV	32	3000	Green (RoHS & no Sb/Br)	CU NIPDAU	Level-2-260C-1 YEAR
TPS51221RTVT	ACTIVE	QFN	RTV	32	250	Green (RoHS & no Sb/Br)	CU NIPDAU	Level-2-260C-1 YEAR
TPS51221RTVTG4	ACTIVE	QFN	RTV	32	250	Green (RoHS & no Sb/Br)	CU NIPDAU	Level-2-260C-1 YEAR

<sup>(1)</sup> The marketing status values are defined as follows:

**ACTIVE:** Product device recommended for new designs.

**LIFEBUY:** TI has announced that the device will be discontinued, and a lifetime-buy period is in effect.

**NRND:** Not recommended for new designs. Device is in production to support existing customers, but TI does not recommend using this part in a new design.

**PREVIEW:** Device has been announced but is not in production. Samples may or may not be available.

**OBSOLETE:** TI has discontinued the production of the device.

<sup>(2)</sup> Eco Plan - The planned eco-friendly classification: Pb-Free (RoHS), Pb-Free (RoHS Exempt), or Green (RoHS & no Sb/Br) - please check <http://www.ti.com/productcontent> for the latest availability information and additional product content details.

**TBD:** The Pb-Free/Green conversion plan has not been defined.

**Pb-Free (RoHS):** TI's terms "Lead-Free" or "Pb-Free" mean semiconductor products that are compatible with the current RoHS requirements for all 6 substances, including the requirement that lead not exceed 0.1% by weight in homogeneous materials. Where designed to be soldered at high temperatures, TI Pb-Free products are suitable for use in specified lead-free processes.

**Pb-Free (RoHS Exempt):** This component has a RoHS exemption for either 1) lead-based flip-chip solder bumps used between the die and package, or 2) lead-based die adhesive used between the die and leadframe. The component is otherwise considered Pb-Free (RoHS compatible) as defined above.

**Green (RoHS & no Sb/Br):** TI defines "Green" to mean Pb-Free (RoHS compatible), and free of Bromine (Br) and Antimony (Sb) based flame retardants (Br or Sb do not exceed 0.1% by weight in homogeneous material)

<sup>(3)</sup> MSL, Peak Temp. -- The Moisture Sensitivity Level rating according to the JEDEC industry standard classifications, and peak solder temperature.

**Important Information and Disclaimer:**The information provided on this page represents TI's knowledge and belief as of the date that it is provided. TI bases its knowledge and belief on information provided by third parties, and makes no representation or warranty as to the accuracy of such information. Efforts are underway to better integrate information from third parties. TI has taken and continues to take reasonable steps to provide representative and accurate information but may not have conducted destructive testing or chemical analysis on incoming materials and chemicals. TI and TI suppliers consider certain information to be proprietary, and thus CAS numbers and other limited information may not be available for release.

In no event shall TI's liability arising out of such information exceed the total purchase price of the TI part(s) at issue in this document sold by TI to Customer on an annual basis.



**TAPE AND REEL INFORMATION**



**QUADRANT ASSIGNMENTS FOR PIN 1 ORIENTATION IN TAPE**



\*All dimensions are nominal

Device	Package Type	Package Drawing	Pins	SPQ	Reel Diameter (mm)	Reel Width W1 (mm)	A0 (mm)	B0 (mm)	K0 (mm)	P1 (mm)	W (mm)	Pin1 Quadrant
TPS51221RTVR	QFN	RTV	32	3000	330.0	12.4	5.3	5.3	1.5	8.0	12.0	Q2
TPS51221RTVT	QFN	RTV	32	250	180.0	12.4	5.3	5.3	1.5	8.0	12.0	Q2

**TAPE AND REEL BOX DIMENSIONS**



\*All dimensions are nominal

Device	Package Type	Package Drawing	Pins	SPQ	Length (mm)	Width (mm)	Height (mm)
TPS51221RTVR	QFN	RTV	32	3000	346.0	346.0	29.0
TPS51221RTVT	QFN	RTV	32	250	190.5	212.7	31.8

RTV (S-PQFP-N32)

PLASTIC QUAD FLATPACK

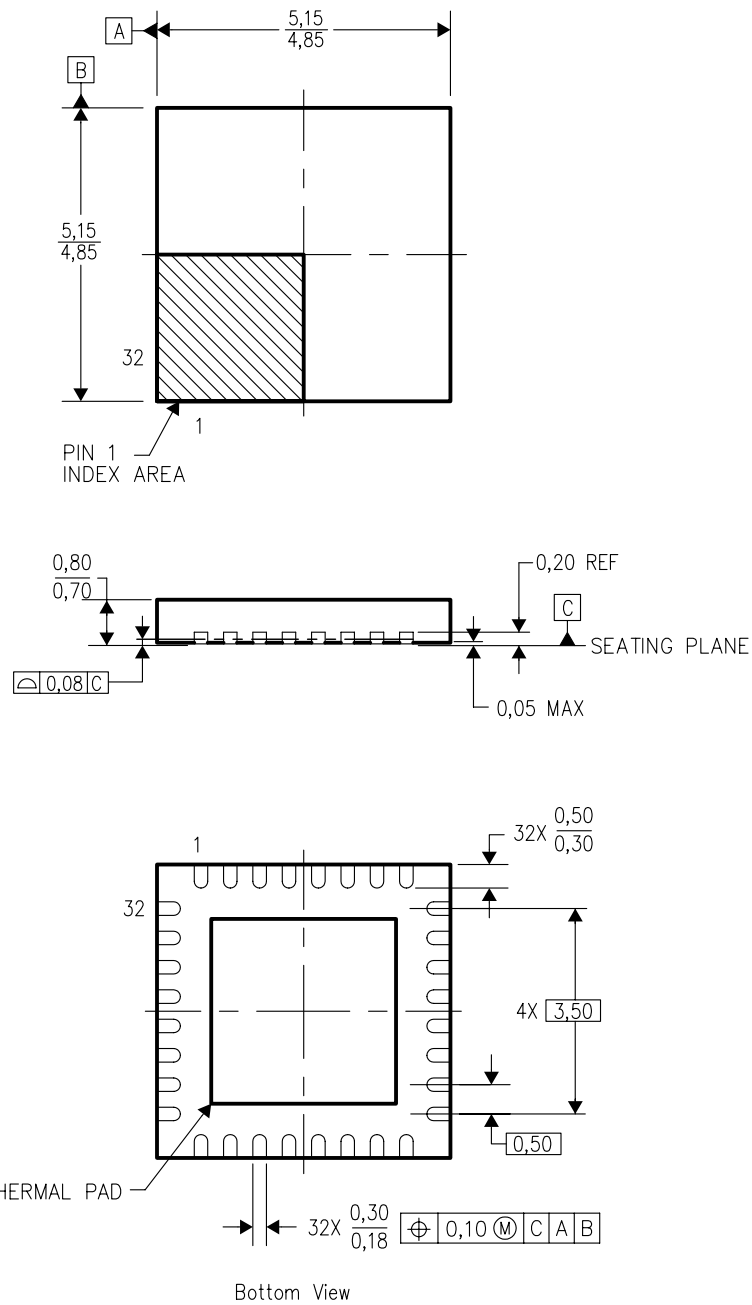

4206245/A 07/04

- NOTES:
- A. All linear dimensions are in millimeters. Dimensioning and tolerancing per ASME Y14.5-1994.
  - B. This drawing is subject to change without notice.
  - C. Quad Flatpack, No-Leads (QFN) package configuration.
  -  The package thermal pad must be soldered to the board for thermal and mechanical performance. See the Product Data Sheet for details regarding the exposed thermal pad dimensions.
  - E. Falls within JEDEC MO-220.

## IMPORTANT NOTICE

Texas Instruments Incorporated and its subsidiaries (TI) reserve the right to make corrections, modifications, enhancements, improvements, and other changes to its products and services at any time and to discontinue any product or service without notice. Customers should obtain the latest relevant information before placing orders and should verify that such information is current and complete. All products are sold subject to TI's terms and conditions of sale supplied at the time of order acknowledgment.

TI warrants performance of its hardware products to the specifications applicable at the time of sale in accordance with TI's standard warranty. Testing and other quality control techniques are used to the extent TI deems necessary to support this warranty. Except where mandated by government requirements, testing of all parameters of each product is not necessarily performed.

TI assumes no liability for applications assistance or customer product design. Customers are responsible for their products and applications using TI components. To minimize the risks associated with customer products and applications, customers should provide adequate design and operating safeguards.

TI does not warrant or represent that any license, either express or implied, is granted under any TI patent right, copyright, mask work right, or other TI intellectual property right relating to any combination, machine, or process in which TI products or services are used. Information published by TI regarding third-party products or services does not constitute a license from TI to use such products or services or a warranty or endorsement thereof. Use of such information may require a license from a third party under the patents or other intellectual property of the third party, or a license from TI under the patents or other intellectual property of TI.

Reproduction of TI information in TI data books or data sheets is permissible only if reproduction is without alteration and is accompanied by all associated warranties, conditions, limitations, and notices. Reproduction of this information with alteration is an unfair and deceptive business practice. TI is not responsible or liable for such altered documentation. Information of third parties may be subject to additional restrictions.

Resale of TI products or services with statements different from or beyond the parameters stated by TI for that product or service voids all express and any implied warranties for the associated TI product or service and is an unfair and deceptive business practice. TI is not responsible or liable for any such statements.

TI products are not authorized for use in safety-critical applications (such as life support) where a failure of the TI product would reasonably be expected to cause severe personal injury or death, unless officers of the parties have executed an agreement specifically governing such use. Buyers represent that they have all necessary expertise in the safety and regulatory ramifications of their applications, and acknowledge and agree that they are solely responsible for all legal, regulatory and safety-related requirements concerning their products and any use of TI products in such safety-critical applications, notwithstanding any applications-related information or support that may be provided by TI. Further, Buyers must fully indemnify TI and its representatives against any damages arising out of the use of TI products in such safety-critical applications.

TI products are neither designed nor intended for use in military/aerospace applications or environments unless the TI products are specifically designated by TI as military-grade or "enhanced plastic." Only products designated by TI as military-grade meet military specifications. Buyers acknowledge and agree that any such use of TI products which TI has not designated as military-grade is solely at the Buyer's risk, and that they are solely responsible for compliance with all legal and regulatory requirements in connection with such use.

TI products are neither designed nor intended for use in automotive applications or environments unless the specific TI products are designated by TI as compliant with ISO/TS 16949 requirements. Buyers acknowledge and agree that, if they use any non-designated products in automotive applications, TI will not be responsible for any failure to meet such requirements.

Following are URLs where you can obtain information on other Texas Instruments products and application solutions:

### Products

Amplifiers	<a href="http://amplifier.ti.com">amplifier.ti.com</a>
Data Converters	<a href="http://dataconverter.ti.com">dataconverter.ti.com</a>
DSP	<a href="http://dsp.ti.com">dsp.ti.com</a>
Clocks and Timers	<a href="http://www.ti.com/clocks">www.ti.com/clocks</a>
Interface	<a href="http://interface.ti.com">interface.ti.com</a>
Logic	<a href="http://logic.ti.com">logic.ti.com</a>
Power Mgmt	<a href="http://power.ti.com">power.ti.com</a>
Microcontrollers	<a href="http://microcontroller.ti.com">microcontroller.ti.com</a>
RFID	<a href="http://www.ti-rfid.com">www.ti-rfid.com</a>
RF/IF and ZigBee® Solutions	<a href="http://www.ti.com/lprf">www.ti.com/lprf</a>

### Applications

Audio	<a href="http://www.ti.com/audio">www.ti.com/audio</a>
Automotive	<a href="http://www.ti.com/automotive">www.ti.com/automotive</a>
Broadband	<a href="http://www.ti.com/broadband">www.ti.com/broadband</a>
Digital Control	<a href="http://www.ti.com/digitalcontrol">www.ti.com/digitalcontrol</a>
Medical	<a href="http://www.ti.com/medical">www.ti.com/medical</a>
Military	<a href="http://www.ti.com/military">www.ti.com/military</a>
Optical Networking	<a href="http://www.ti.com/opticalnetwork">www.ti.com/opticalnetwork</a>
Security	<a href="http://www.ti.com/security">www.ti.com/security</a>
Telephony	<a href="http://www.ti.com/telephony">www.ti.com/telephony</a>
Video & Imaging	<a href="http://www.ti.com/video">www.ti.com/video</a>
Wireless	<a href="http://www.ti.com/wireless">www.ti.com/wireless</a>

Mailing Address: Texas Instruments, Post Office Box 655303, Dallas, Texas 75265  
Copyright © 2008, Texas Instruments Incorporated